

ET 405 Heat pump for cooling and heating operation

With suitable arrangement of compressor, condenser and evaporator, the same heat pump can be used for heating and for cooling. In the air-conditioning of buildings, this is advantageous since rooms are heated in winter and cooled in summer by the same system. In addition, heat pumps are already widely used to generate hot water. The heat source always plays a central role in heat pump technology. The design of the heat pump is particularly important in order to be able to use the existing heat sources effectively at a low temperature level.

ET 405 enables the investigation of a multitude of component arrangement options. A compressor, a condenser (heat exchanger with fan) and two evaporators with fans (standard cooling stage and deep-freeze stage) are available. A coaxial coil heat exchanger can optionally be operated as an evaporator or a condenser. It connects the heat pump circuit to another circuit filled with a glycol-water mixture.

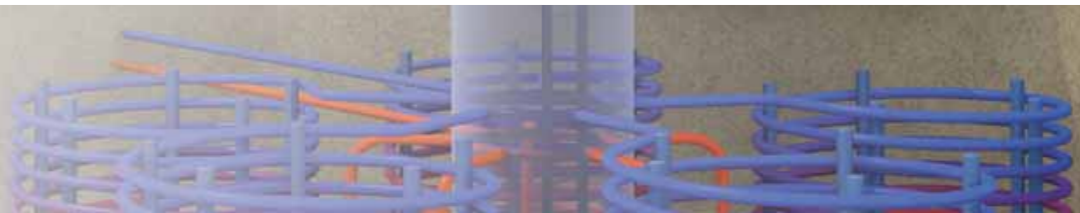

Different operating modes for typical applications

Two evaporators – connected in series or parallel

The two evaporators can optionally be connected parallel or in series. It is also possible to operate only one evaporator. The condenser 9 operates as an air heater. At both evaporators 3 the heat is absorbed from the environment.

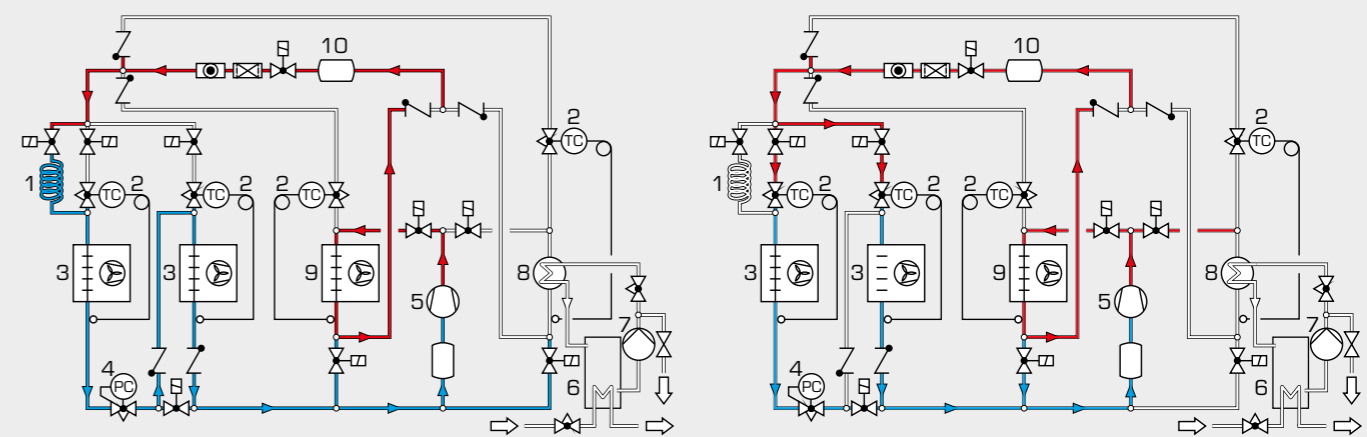

1 capillary tube, 2 expansion valve, 3 evaporator, 4 evaporation pressure controller, 5 compressor, 6 tank for glycol-water mixture, 7 pump, 8 coaxial coil heat exchanger, 9 heat exchanger with fan, 10 receiver

Coaxial coil heat exchanger as evaporator (cooling)

The liquid refrigerant is expanded using a thermostatic expansion valve 2 and evaporated in the coaxial coil heat exchanger 8. This cools the glycol-water mixture. The condensation of the refrigerant takes place in the air-cooled finned tube heat exchanger 9. In the tank 6 the glycol-water mixture absorbs heat from the pipe coil through which water flows.

Coaxial coil heat exchanger as condenser (heating)

The refrigerant steam flows through the coaxial coil heat exchanger 8. Here the refrigerant is condensed and heats the glycol-water mixture. The refrigerant then flows through two evaporators 3 which can optionally be connected in parallel or in series. The glycol-water mixture discharges its heat in the tank 6 to a water-cooled pipe coil.

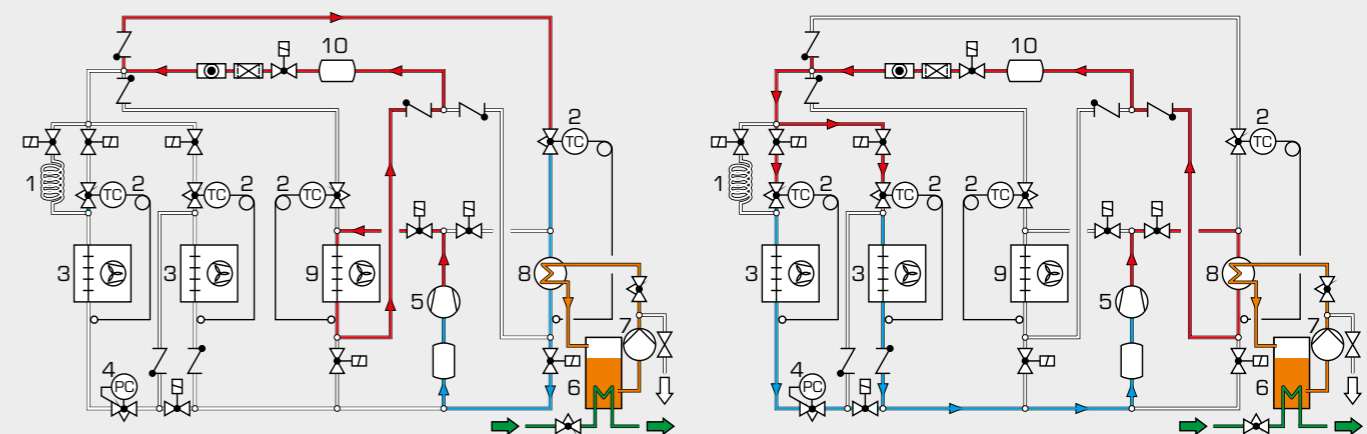

Cooling and heating using the heat pump

Cooling

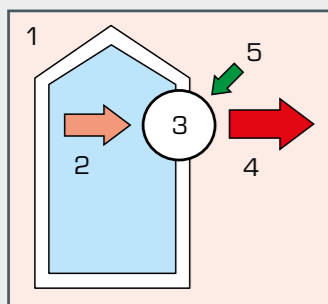

During cooling the absorbed heat at the heat pump provides the gain. It is absorbed from a room and discharged into the environment. Electrical energy to operate the compressor of the heat pump is required for this purpose.

Heating

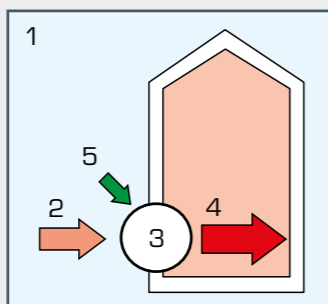

During heating the heat discharged by the heat pump is the gain. The heat pump absorbs heat from the environment and discharges it to the room.

1 environment, 2 absorbed heat, 3 heat pump, 4 discharged heat, 5 electric energy