

Overview

CE 322 Rheology and mixing quality in a stirred tank

Mixing processes are largely determined by the flow properties of the substances being mixed. The study of flow properties is called **rheology**. This device allows you to determine all characteristic variables for describing a stirring process. These include mixing characteristics and power curves.

The main component of the device is a high-grade stirring machine with an integrated device for measuring the torque. The stirring process takes place in a circular glass vessel. This provides ideal conditions for observing the stirring process. When using a salt solution, the progress of the stirring process can be reliably recorded by measuring the electrical conductivity. A large selection of different types of stirrer allows a wide range of experiments. The following types of stirrer are included:

- pitched-blade stirrer
- propeller stirrer
- blade stirrer
- turbine stirrer

The stirred tank can be equipped with baffles. The number and position of these baffles can be varied. The viscosity of the medium is critical to the stirring process. Since the viscosity depends on the temperature, a heat exchanger in the form of a coiled tube can be inserted into the stirred tank.

Stirrer types

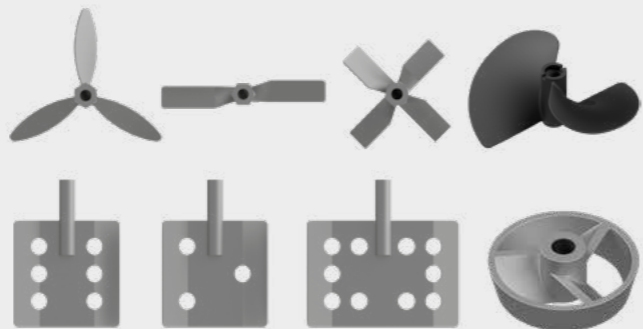

About the product:



- 1 stirred tank
- 2 flow meter
- 3 flow controller
- 4 temperature controller
- 5 digital display for conductivity
- 6 conductivity sensor
- 7 temperature sensor
- 8 stirring machine with torque measurement
- 9 connections for hot and cold water



Stirred tank with built-in heat exchanger

Power curves

A power curve represents the power number N_p as a function of the Reynolds number. Using the power number, it is possible to determine the required power output of a stirring machine, which is essential for the dimensioning of a stirring machine. The profile of a power curve depends on the type of stirrer.

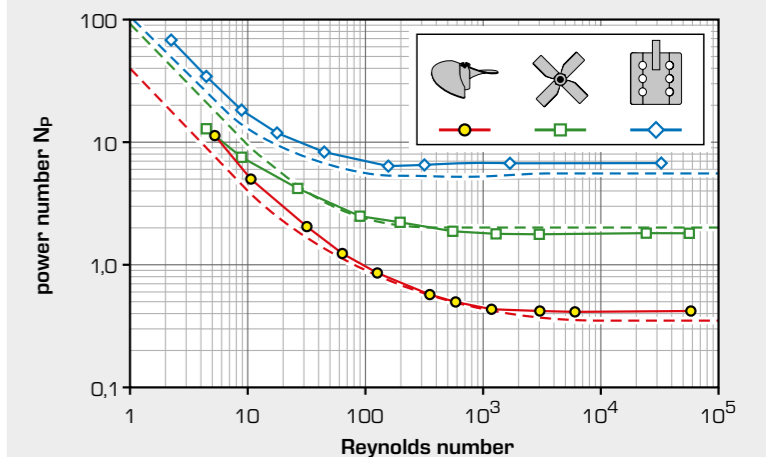

Power curves measured with CE 322 compared to characteristics from technical literature

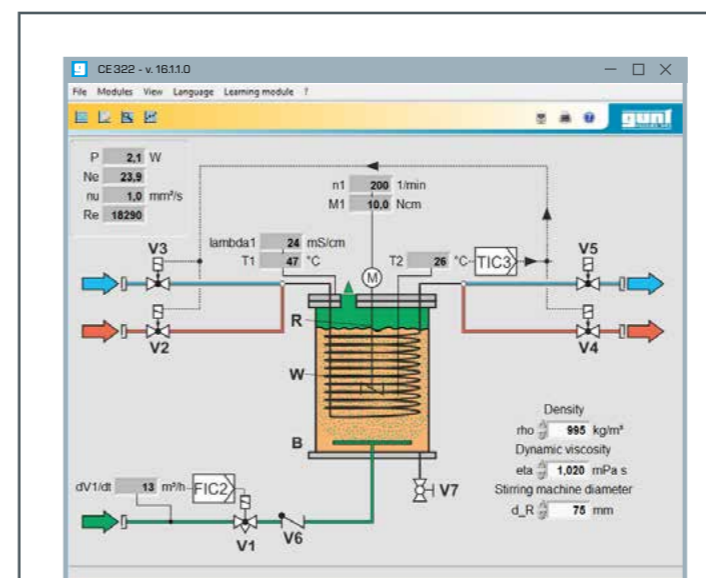

Software of CE 322

Software

The measured values are displayed digitally and can simultaneously be transmitted via USB directly to a PC, where they can be stored using the software included.

Learning objectives

- determination of mixing characteristics
 - ▶ mixing time and degree of mixing
 - ▶ mixing time key figure
- determination of power curves
 - ▶ power demand
 - ▶ power number (Newton number)
- influence of
 - ▶ stirrer type
 - ▶ geometric relationships
 - ▶ speed
 - ▶ substance properties (density, viscosity)
- evaluation of flow state by Reynolds' number (laminar, turbulent)
- mode of action of baffles
- gassing and heat exchange in stirred tanks
- observation of flow fields of different stirrer types for solutions, emulsions and suspensions