

MT 156

Assembly exercise: wedge gate valve and angle seat valve



The illustration shows the tool box with kits and tools. In the foreground the valves and fittings as they are assembled from the kits.

Description

- **practical exercise based on the assembly of a wedge gate valve and an angle seat valve**
- **comprehensive and well-structured instructional material**

Wedge gate valves are used as fittings for water, water vapour, oil and other non-aggressive liquids. Operating temperatures of up to 200°C are possible. Wedge gate valves in this design are operated by a hand-wheel turned spindle. During closing, the slider is pushed by the spindle nut into the sealing rings in the housing.

Angle seat valves are the typical fittings used in drinking water pipes. Angle seat valves are also used in many areas of industry. They are designed for neutral fluids and gaseous media. Stainless steel versions are suitable for mildly and highly aggressive media. The valves can be used for high flow rates, and are non-sensitive to lightly contaminated and high-viscosity media. The valve spindle is usually arranged at a 45° angle to the direction of flow. Angle seat valves generate substantially lower pressure loss than screw down valves or corner valves owing to the less tortuous flow path of the fluid.

The MT 156 practice kit forms part of the GUNT Practice Line for assembly, maintenance and repair designed for training at technical colleges and in company training centres. A close link between theory and practice is key to the learning content.

MT 156 enables two typical industrially relevant valves and fittings to be assembled and disassembled. Students become familiar with all the components and their modes of operation. The parts are clearly laid out and well protected in a tool box. Systematic assembly and disassembly of the valves is practiced. The accompanying material details the individual steps involved in assembly, and provides additional information on the areas of application, mode of operation and design of the valves and fittings.

Learning objectives/experiments

- design and function of a wedge gate valve
- design and function of an angle seat valve
- assembly and disassembly, including for the purposes of maintenance and repair
- replacing components (e.g. seal)
- comparison of 2 different valves and fittings
- reading and understanding engineering drawings and operating instructions
- together with the valves and fittings test stand MT 162
 - ▶ leak testing of the assembled valve

MT 156

Assembly exercise: wedge gate valve and angle seat valve



Assembly of the slider

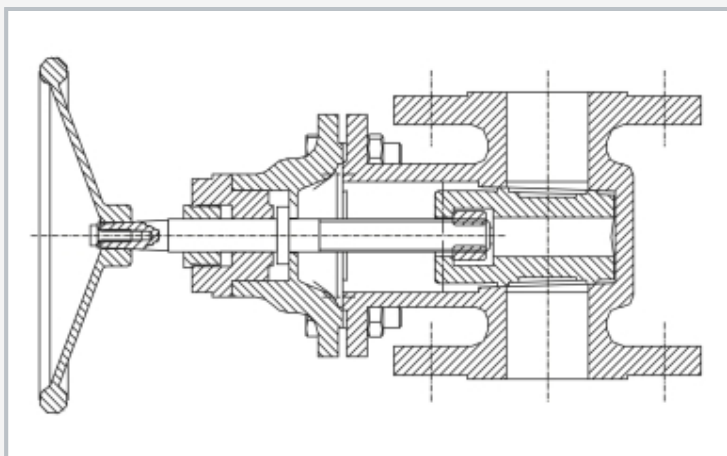

Sectional drawing of the wedge gate valve

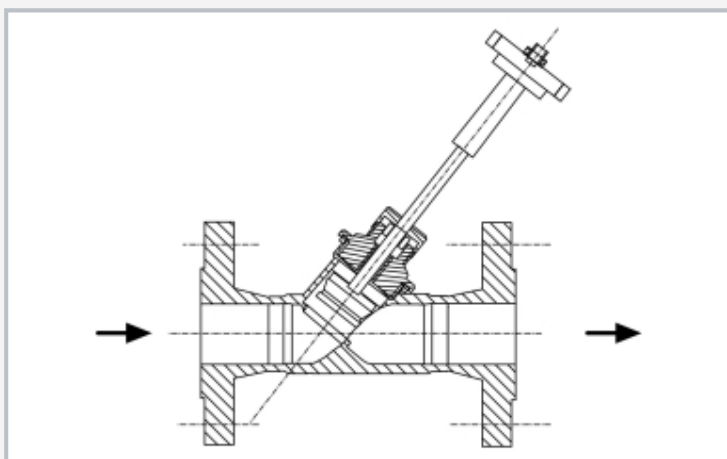

Sectional drawing of the angle seat valve

Specification

- [1] learning concept for assembly exercises on valves and fittings
- [2] wedge gate valve with hand wheel, as set of parts
- [3] angle seat valve with manual drive, as set of parts
- [4] complete assembly tool kit
- [5] valve parts and tools housed in a sheet-steel tool box
- [6] part of the GUNT Practice Line for assembly, maintenance and repair

Technical data

Wedge gate valve with flange connections

- DN40, PN10
- materials: housing, cover, taper: grey cast iron; spindle, sealing surfaces of housing and taper: stainless steel; packing rings: graphite

Angle seat valve with flange connections

- DN25, PN16
- materials: housing: stainless steel; metallic inner parts: stainless steel; seals: PTFE

LxWxH: 720x360x310mm (tool box)

Weight: approx. 35kg

Scope of delivery

- 1 kit (wedge gate valve)
- 1 kit (angle seat valve)
- 1 set of tools
- 1 set of small parts
- 1 tool box with foam inlay
- 1 set of instructional material, consisting of: technical description of system, complete set of drawings with lists of parts, description of assembly and disassembly sequences, also in relation to repair operations

MT 156

Assembly exercise: wedge gate valve and angle seat valve

Optional accessories

051.16200

MT 162

Hydraulic valves and fittings test stand