

# HM 305

## Centrifugal pump trainer



### Description

- principle of operation of a centrifugal pump
- closed water circuit
- centrifugal pump, standard design

Centrifugal pumps are turbomachines that are used for conveying fluids. In centrifugal pumps, the head depends on the flow rate. This dependency is understood to be the operating behaviour of the pump and is represented in the characteristic diagram of the pump.

The trainer HM 305 is intended for experiments on the fundamental behaviour of a hydraulic circuit. HM 305 is suitable for both training in vocational colleges and for laboratory experiments in higher education.

The equipment of the trainer includes a closed water circuit and a powerful, standard centrifugal pump. Standard pumps are built according to industrial standards. The standard defines rating schemes and key dimensions so that standard pumps from different manufacturers can be exchanged without replacing the piping and ground plate.

The centrifugal pump is powered by a three-phase motor. The speed can be adjusted to the desired value with the frequency converter. An inductive, non-contact position encoder on the engine shaft records the speed. The drive motor is mounted in a pendulum bearing such that the drive torque can be measured with a force sensor and the mechanical drive power can be determined.

Manometers display the pressure on the pump's inlet and outlet. The flow rate is measured with an electromagnetic flow rate sensor. The flow rate can also be determined by means of a differential pressure measurement on an orifice plate flow meter.

The speed, torque, and electrical power consumption of the pump and the flow rate are shown on a digital display on the switch cabinet.

### Learning objectives/experiments

- recording of pump characteristics
- recording of system characteristics
- determination of the flow rate by means of an electromagnetic flow rate sensor or an orifice plate flow meter and a differential pressure measurement
- calculation of efficiencies

# HM 305

## Centrifugal pump trainer

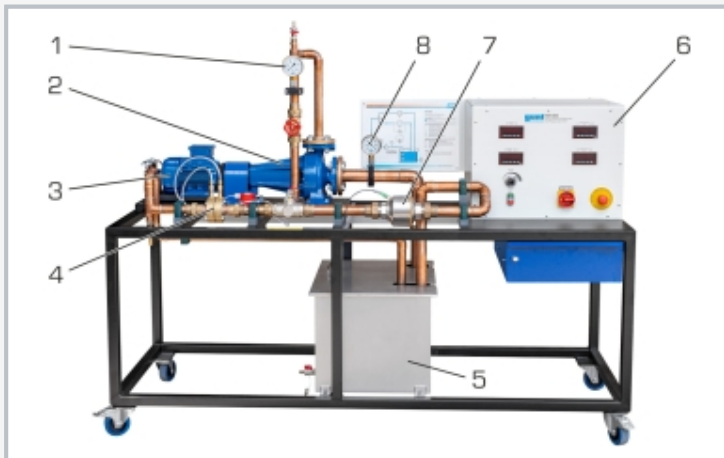

1 outlet manometer, 2 centrifugal pump, 3 drive motor, 4 orifice plate flow meter, 5 tank, 6 switch cabinet with display and control elements, 7 electromagnetic flow meter, 8 inlet manometer

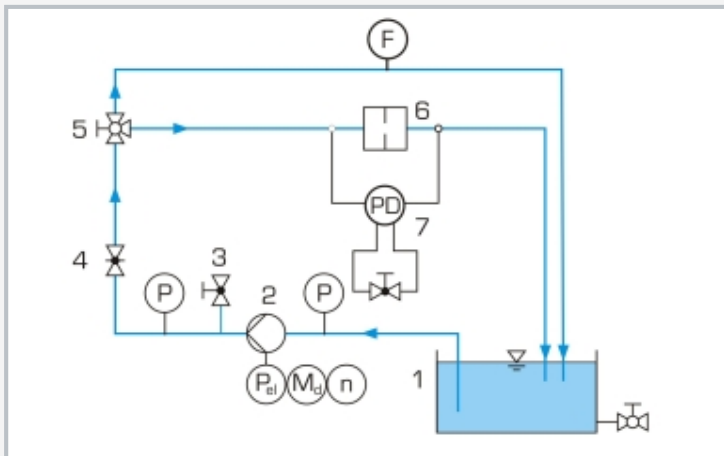

1 tank, 2 pump, 3 water connection for filling, 4 gate valve, 5 3-way valve, 6 orifice plate flow meter, 7 differential pressure sensor with bleed valve  
P pressure, F flow rate,  $P_{el}$  power,  $n$  speed,  $M_t$  torque

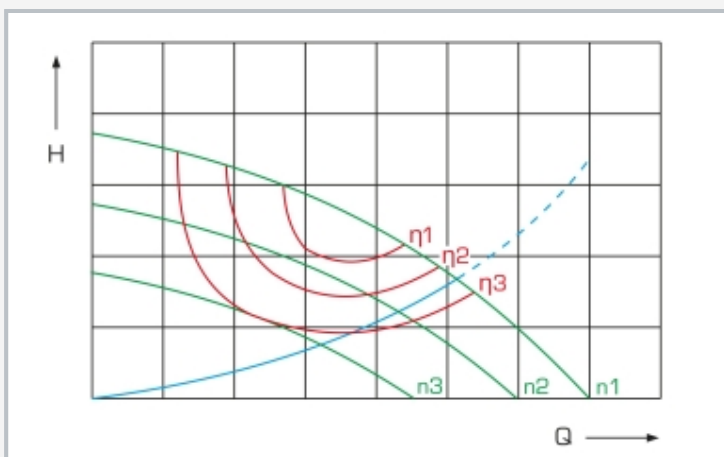

Characteristic diagram of the centrifugal pump  
green: pump characteristics for different speeds, blue: system characteristics, red: characteristics of constant efficiencies  
H head, Q flow, n speed

### Specification

- [1] examination of a standard centrifugal pump
- [2] closed water circuit
- [3] three-phase motor to power the pump with variable speed via a frequency converter
- [4] drive motor with pendulum bearing
- [5] non-contact speed measurement at the engine shaft and force sensor for measuring the drive power
- [6] determination of the flow rate by using an electromagnetic flow rate sensor, or an orifice plate flow meter and a differential pressure measurement
- [7] manometer at the inlet and outlet of the centrifugal pump
- [8] digital displays for torque, speed, electrical power consumption and flow

### Technical data

#### Centrifugal pump

- max. flow rate: approx.  $20\text{m}^3/\text{h}$
- max. head: approx. 23m

#### Drive motor with variable speed

- power output: 1,1kW
- speed range:  $0\text{...}2900\text{min}^{-1}$

#### Tank

- volume: 96L

#### Measuring ranges

- pressure: 1x  $0,6\text{...}0\text{bar}$ , 1x  $0\text{...}2,5\text{bar}$
- flow rate:  $5\text{...}600\text{L}/\text{min}$
- speed:  $0\text{...}5000\text{min}^{-1}$
- torque:  $0\text{...}10\text{Nm}$
- power consumption:  $0\text{...}2,2\text{kW}$

230V, 50Hz, 1 phase  
 230V, 60Hz, 1 phase  
 230V, 60Hz, 3 phases  
 LxWxH: 2000x750x1480mm  
 Weight: approx. 215kg

### Scope of delivery

- 1 trainer
- 1 set of accessories
- 1 set of instructional material