

HM 225.02

Boundary layers



Learning objectives/experiments

- internal friction of gases
- investigation of the boundary layer on the flat plate
- influence of surface roughness on the formation of a boundary layer
- boundary layer interference with degressive/progressive pressure curve

Description

- investigation of the boundary layer at two different rough surfaces
- boundary layer interference with pressure profile
- accessories for aerodynamics trainer HM 225

During incident flow of bodies fluids such as air "stick" to the surface of the body and form the so-called boundary layer. The kind of flow within the boundary layer – laminar or turbulent – significantly affects the drag. The findings from studying the boundary layer are taken into consideration when designing aeroplanes, vessels and turbomachines.

The HM 225.02 experimental unit – used in the aerodynamics trainer HM 225 – allows the boundary layer on a flat plate to be studied. For this purpose, air flows along the plate, parallel to the surface. The plate has two different surfaces so as to study the effect of surface conditions on the boundary layer. Side bodies can be used in the measuring section. Thus the boundary layer phenomena can experience interference with a degressive or progressive pressure curve and, for example equalise the friction loss of the flow.

A horizontally movable Pitot tube, adjusted using a micrometer screw, measures the total pressures at various distances from the plate surface. The plate can be moved vertically to enable the recording of total pressures in the direction of flow. The velocity can be determined from the pressures read off the tube manometers in HM 225.

The experimental unit is attached to the HM 225 trainer, simply and precisely with quick release fasteners.

HM 225.02

Boundary layers

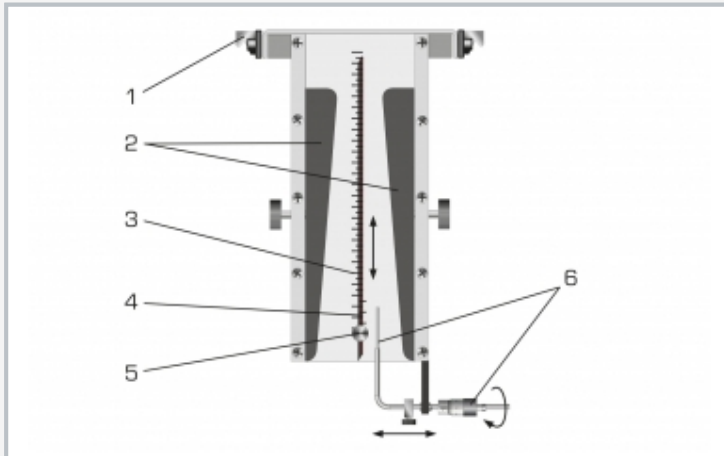

1 quick release fastener for connecting to HM 225, 2 removable side bodies, 3 scale, 4 plate with different surfaces, 5 vertical adjustment of the plate, 6 Pitot tube with micrometer screw for horizontal adjustment



Experimental setup: 1 HM 225, 2 HM 225.02, 3 tube manometers (HM 225) with connection to HM 225.02

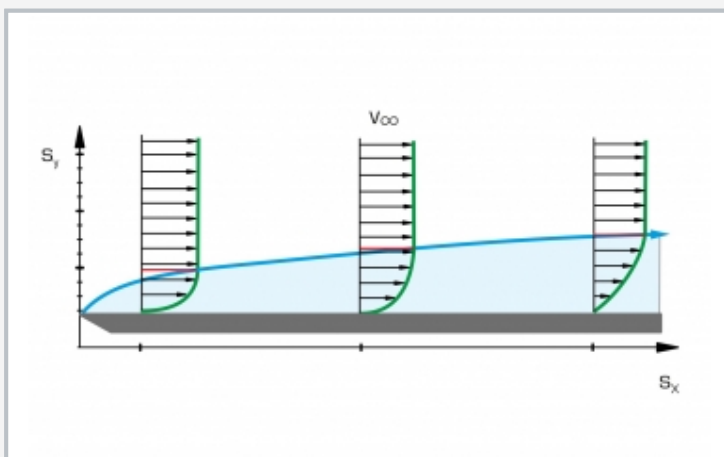

Velocity distribution and boundary layer thickness in the boundary layer of a flat plate; S_y distance from the surface, S_x distance from leading edge, green: distribution of the velocity, blue: boundary layer thickness

Specification

- [1] investigation of boundary layers on a flat plate with flow along the plate
- [2] accessories for the aerodynamics trainer HM 225
- [3] plate with two different rough surfaces
- [4] moveable plate, along the direction of flow
- [5] Pitot tube for measuring the total pressure at the plate
- [6] adjustment of the Pitot tube to the plate using micrometer screw
- [7] removable side bodies for interference of the boundary layer with degressive or progressive pressure profile
- [8] 16 tube manometers of HM 225 for displaying the dynamic pressures

Technical data

Pitot tube

- diameter: 0,7mm
- movable: 0,35...50mm

Plate, movable: 0...250mm

- LxW: 260x55mm, thickness: 5mm
- chamfer: 30°
- smooth surface: 25 μ m
- rough surface: 400 μ m

2 side bodies, removable

- inclination: 1:12,5

LxWxH: 220x130x300mm

Weight: approx. 4kg

Scope of delivery

- 1 experimental unit
- 1 plate
- 2 side bodies
- 1 set of instructional material

HM 225.02

Boundary layers

Required accessories

070.22500 HM 225 Aerodynamics trainer