

# HM 162

## Experimental flume 309x450mm



HM 162 (7,5m experimental section) with the wave generator HM 162.41 and the level gauge HM 162.52, screen mirroring is possible on different end devices

### Description

- experiments ranging from fundamental principles to research projects, experimental section of 5m, 7,5m, 10m and 12,5m available
- plant control using an integrated PLC
- integrated router for operation and control via an end device and for screen mirroring on additional end devices: PC, tablet, smartphone
- models from all fields of hydraulic engineering available as accessories

Experimental flumes are used in teaching and research to demonstrate and study the main phenomena of open-channel flow at the laboratory scale. For example, control structures for flow regulation and various methods of flow measurement are demonstrated.

The experimental flume HM 162 has a closed water circuit and an extendable experimental section. The side walls of the experimental section are made of tempered glass, which allows excellent observation of the experiments. All components that come into contact with water are made of corrosion-resistant materials.

The inlet element is designed so that the flow enters the experimental section with very little turbulence.

The inclination of the experimental flume can be finely adjusted to allow simulation of slope and to create a uniform flow at a constant discharge depth.

A wide selection of models, such as weirs, piers, flow-measuring flumes or a wave generator are available as accessories and ensure a comprehensive programme of experiments. Most models are quickly and safely bolted to the bottom of the experimental section.

The flume is controlled by the PLC via touch screen. By means of an integrated router, the flume can alternatively be operated and controlled via an end device. The user interface can also be displayed on additional end devices (screen mirroring). Via the PLC, the measured values can be stored internally. Access to stored measured values is possible from end devices via WLAN with integrated router/LAN connection to the customer's own network. Via direct LAN connection the measured values can also be transmitted to a PC where they can be analysed using the GUNT software. For experiment observation in remote learning, the use of a camera is necessary.

### Learning objectives/experiments

- together with optionally available models
  - ▶ uniform and non-uniform discharge
  - ▶ flow formulae
  - ▶ flow transition (hydraulic jump)
  - ▶ energy dissipation (hydraulic jump, stilling basin)
  - ▶ flow over control structures: weirs (sharp-crested, broad-crested, ogee-crested)
  - ▶ flow over control structures: discharge under gates
  - ▶ flow-measuring flumes
  - ▶ local losses due to obstacles
  - ▶ transient flow: waves
  - ▶ vibrating piles
  - ▶ sediment transport
- screen mirroring: mirroring of the user interface on end devices
  - ▶ menu navigation independent of the user interface shown on the touch screen
  - ▶ different user levels available on the end device: for observing the experiments or for operation and control

# HM 162

## Experimental flume 309x450mm

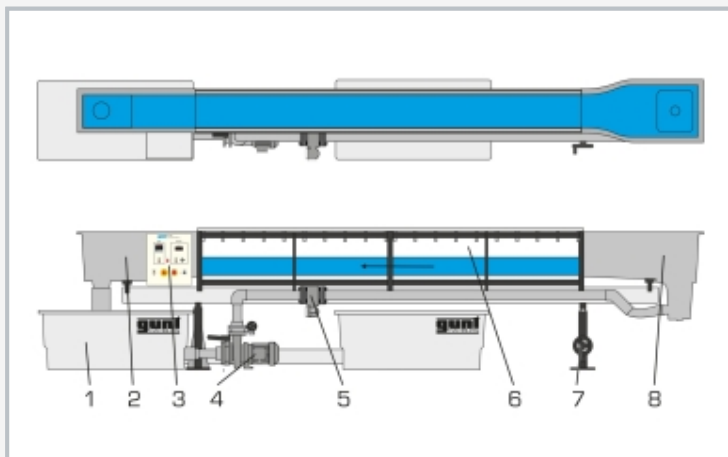

1 water tank, 2 outlet element, 3 switch box, 4 pump, 5 flow rate sensor, 6 experimental section, 7 inclination adjustment, 8 inlet element

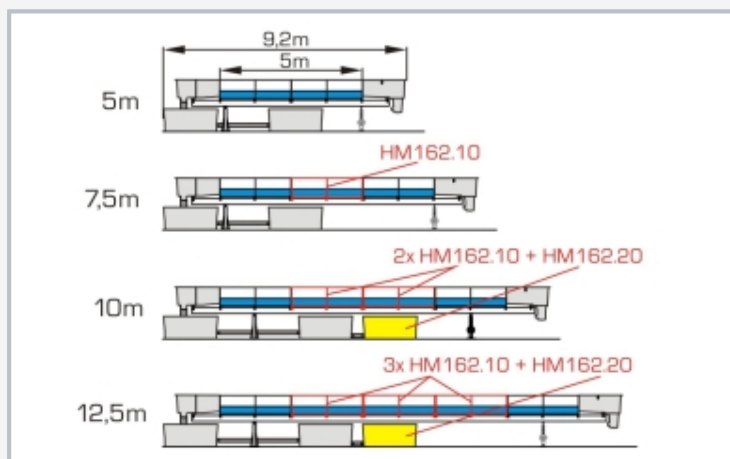

HM 162 with experimental sections of different lengths (5...12,5m). Depending on the desired length, additional extension elements HM 162.10 and water tanks HM 162.20 are required.

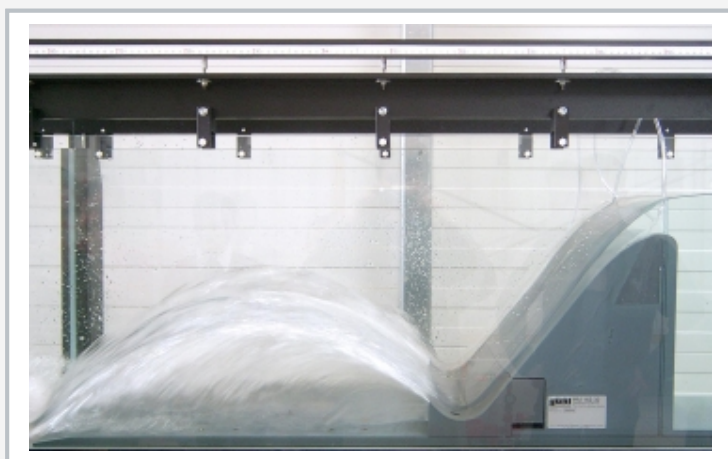

Overflow at ogee-crested weir with ski jump spillway HM 162.32.

### Specification

- [1] basic principles of open-channel flow
- [2] experimental flume with experimental section, inlet and outlet element and closed water circuit
- [3] length of the experimental section 5m, up to 12,5m possible with additional extension elements HM 162.10
- [4] smoothly adjustable inclination of the experimental section
- [5] experimental section with 20 evenly spaced threaded holes on the bottom for installing models or for water level measurement using pressure
- [6] side walls of the experimental section are made of tempered glass for excellent observation of the experiments
- [7] experimental section with guide rails for the optionally available instrument carrier HM 162.59
- [8] all surfaces in contact with water are made of corrosion-resistant materials: stainless steel, glass reinforced plastic
- [9] flow-optimised inlet element for low-turbulence entry into the experimental section
- [10] closed water circuit with 2 water tanks, pump, electromagnetic flow sensor and flow control
- [11] models from all fields of hydraulic engineering available as accessories
- [12] flume control with PLC via touch screen
- [13] integrated router for operation and control via an end device and for screen mirroring: mirroring of the user interface on up to 5 end devices
- [14] data acquisition via PLC on internal memory, access to stored measured values via WLAN with integrated router/ LAN connection to customer's own network
- [15] GUNT software for data acquisition via LAN under Windows 10

### Technical data

#### Experimental section

- possible lengths: 5m-7,5m-10m-12,5m
- flow cross-section WxH: 309x450mm
- inclination adjustment: -0,5...+2,5%

2 tanks, made of GRP, 1100L each

#### Pump

- power consumption: 4,75kW
- max. flow rate: 132m<sup>3</sup>/h
- max. head: 16,1m
- speed: 1450min<sup>-1</sup>

#### Measuring ranges

- flow rate: 5,4...130m<sup>3</sup>/h

400V, 50Hz, 3 phases, 400V, 60Hz, 3 phases

230V, 60Hz, 3 phases, UL/CSA optional

LxWxH: 9170x1000x2100mm (experim. section 5m)

Empty weight: approx. 1800kg

### Required for operation

PC with Windows

### Scope of delivery

experimental flume, set of tools, GUNT software, set of instructional material

# HM 162

## Experimental flume 309x450mm

### Optional accessories

#### Control structures

070.16229	HM 162.29	Sluice gate
070.16240	HM 162.40	Radial gate
070.16230	HM 162.30	Set of plate weirs, four types
070.16231	HM 162.31	Broad-crested weir
070.16233	HM 162.33	Crump weir
070.16236	HM 162.36	Siphon weir
070.16238	HM 162.38	Rake
070.16234	HM 162.34	Ogee-crested weir with pressure measurement
070.16232	HM 162.32	Ogee-crested weir with two weir outlets
070.16235	HM 162.35	Elements for energy dissipation

#### Change in cross-section

070.16244	HM 162.44	Sill
070.16245	HM 162.45	Culvert
070.16246	HM 162.46	Set of piers, seven profiles
070.16277	HM 162.77	Flume bottom with pebble stones

#### Flow-measuring flumes

070.16251	HM 162.51	Venturi flume
070.16255	HM 162.55	Parshall flume
070.16263	HM 162.63	Trapezoidal flume

#### Other experiments

070.16241	HM 162.41	Wave generator
070.16280	HM 162.80	Set of beaches
070.16261	HM 162.61	Vibrating piles
070.16271	HM 162.71	Closed sediment circuit
070.16272	HM 162.72	Sediment trap
070.16273	HM 162.73	Sediment feeder

#### Measuring instruments

070.16252	HM 162.52	Level gauge
070.16291	HM 162.91	Digital level gauge
070.16264	HM 162.64	Velocity meter
070.16250	HM 162.50	Pitotstatic tube
070.16253	HM 162.53	Ten tube manometers
070.16213	HM 162.13	Electronic pressure measurement
070.16259	HM 162.59	Instrument carrier
070.16281	HM 162.81	PIV-System
070.16282	HM 162.82	Instrument carrier for PIV system
070.16283	HM 162.83	Glass cut-out for PIV system

#### Other accessories

070.16257	HM 162.57	Electrical inclination adjustment
070.16210	HM 162.10	Extension element of the experimental flume
070.16220	HM 162.20	Water tank
070.16214	HM 162.14	Gallery
070.16215	HM 162.15	Extension element of the gallery