

CE 602

Discontinuous rectification



Learning objectives/experiments

- investigation and comparison of sieve tray and packed columns
 - ▶ in discontinuous mode
 - ▶ in vacuum mode
 - ▶ with different reflux ratios
 - ▶ with different numbers of trays
- determination of concentration profiles
- determination of temperature profiles
- pressure loss over the column

Description

- discontinuous rectification
- comparison of packed and sieve tray column
- vacuum mode possible
- trays in sieve tray column removable

Distillation is used to separate liquid mixtures made up of individual liquids that are soluble in one another. Rectification refers to distillation in a counterflow. Ethanol/water is recommended as the liquid mixture for the CE 602. The liquid mixture is added to the evaporator (bottom) tank. The mixed vapour produced moves upwards in the column. The mixed vapour contains a higher concentration of the component with the lower boiling point (ethanol). It leaves the top of the column and is condensed using a condenser and a phase separation tank.

Part of the condensate is collected in a tank as product while the rest is fed back into the column. Here, on its way downwards, it undergoes further heating and material exchange with the rising mixed vapour. This exchange causes the vapour phase to become richer in ethanol and the liquid phase to become richer in water. The liquid phase moves to the bottom where it is collected.

A sieve tray column and a packed column are available. The packed column is filled with Raschig rings. The reflux ratio is adjusted using valves.

Relevant measured values are recorded by sensors and displayed digitally on the switch cabinet. The evaporator is adjusted using a PID controller.

A large, clear process schematic on the switch cabinet makes it easy to assign all the process variables.

CE 602

Discontinuous rectification

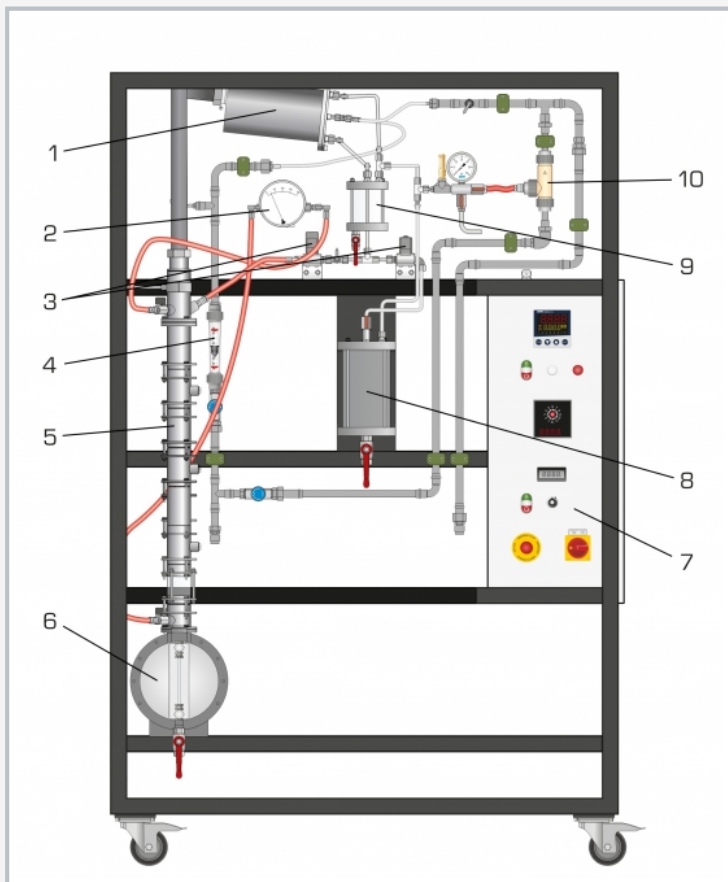

1 top product condenser, 2 manometer (column differential pressure), 3 valves (reflux ratio), 4 cooling water flow meter, 5 sieve tray or packed column, 6 evaporator, 7 switch cabinet with displays and controls, 8 top product tank, 9 phase separation tank, 10 water jet pump

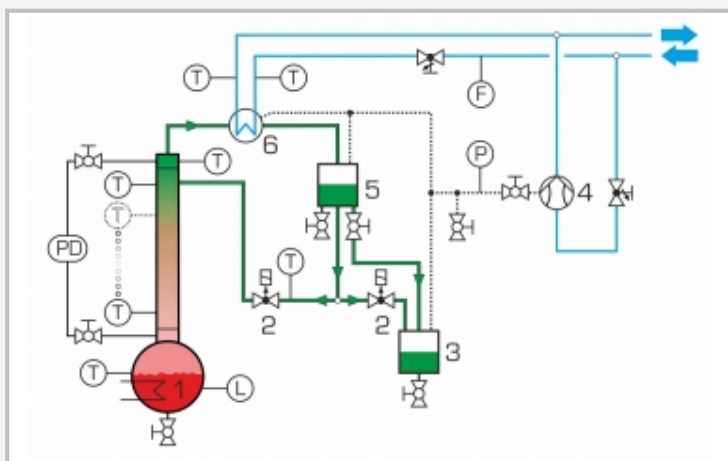

1 evaporator with column, 2 valves (reflux ratio), 3 top product tank, 4 water jet pump, 5 phase separation tank, 6 condenser; F flow rate, L level, P pressure, PD differential pressure, T temperature; blue line: cooling water

Specification

- [1] discontinuous rectification with packed and sieve tray column
- [2] interchangeable columns
- [3] sieve tray column with 8 trays
- [4] packed column with Raschig rings
- [5] vacuum mode possible with water jet pump
- [6] electrically heated evaporator
- [7] tank for top product
- [8] condenser and phase separation tank for top product
- [9] all tanks made of DURAN glass and stainless steel
- [10] adjustment of reflux ratio using valves
- [11] 8 temperature measuring points per column

Technical data

Columns: internal diameter: 50mm, height: 765mm
 Water jet pump: final vacuum: approx. 200mbar
 Tanks
 ■ top product: approx. 2000mL
 ■ phase separation: approx. 500mL

Evaporator

- power output: 0...4kW
- tank: approx. 10L

Heat transfer surface

- top product condenser: approx. 0,04m²

Measuring ranges

- temperature: 13x 0...150°C
- reflux ratio: 0...100%
- flow rate: 30...320L/h (cooling water)
- differential pressure: 0...60mbar (column)
- manometer: -1...0,6bar

400V, 50Hz, 3 phases

230V, 60Hz, 3 phases, 400V, 60Hz, 3 phases

UL/CSA optional

LxWxH: 1300x750x2100mm

Weight: approx. 210kg

Required for operation

water connection: 500...1000L/h, drain

Scope of delivery

- 1 trainer
- 1 column
- 1 set of hoses
- 1 set of accessories
- 1 set of instructional material