

CE 584

Advanced oxidation



Learning objectives/experiments

- familiarisation with oxidation with hydrogen peroxide and UV light
- recording of degradation curves for the investigation of reaction kinetics
- influence of the hydrogen peroxide quantity on the process

Description

- **oxidation of organic substances with hydrogen peroxide (H_2O_2) and UV light**
- **discontinuous operation with falling film reactor**

In water treatment oxidation processes are used to remove organic substances which are not biodegradable. If the oxidation is by hydroxyl radicals (OH radicals) it is called "advanced oxidation". A common method for forming hydroxyl radicals is the irradiation of hydrogen peroxide with UV light. CE 584 demonstrates this process using a discontinuous falling film reactor.

The falling film reactor consists of a transparent tube which is open at the bottom. At the top of the tube there is a circular channel.

Using a pump the raw water enriched with hydrogen peroxide is transported from a tank into the channel. From here the water flows as a thin falling film along the inside wall of the tube back into the tank. This creates a closed water circuit. At the centre of the tube there is a UV lamp. By irradiation of the falling raw water with UV light hydroxyl radicals form from the hydrogen peroxide molecules. The hydroxyl radicals oxidate the organic non-biodegradable substances in the raw water. As protection against the radiation the UV lamp is fitted with a protective tube.

The flow rate and temperature of the water are continuously measured. The temperature is indicated digitally in the switch cabinet. Samples can be taken at the tank.

E.g. triethylene glycol dimethyl ether can be used to produce the raw water. Analysis technology is required to evaluate the experiments.

CE 584

Advanced oxidation

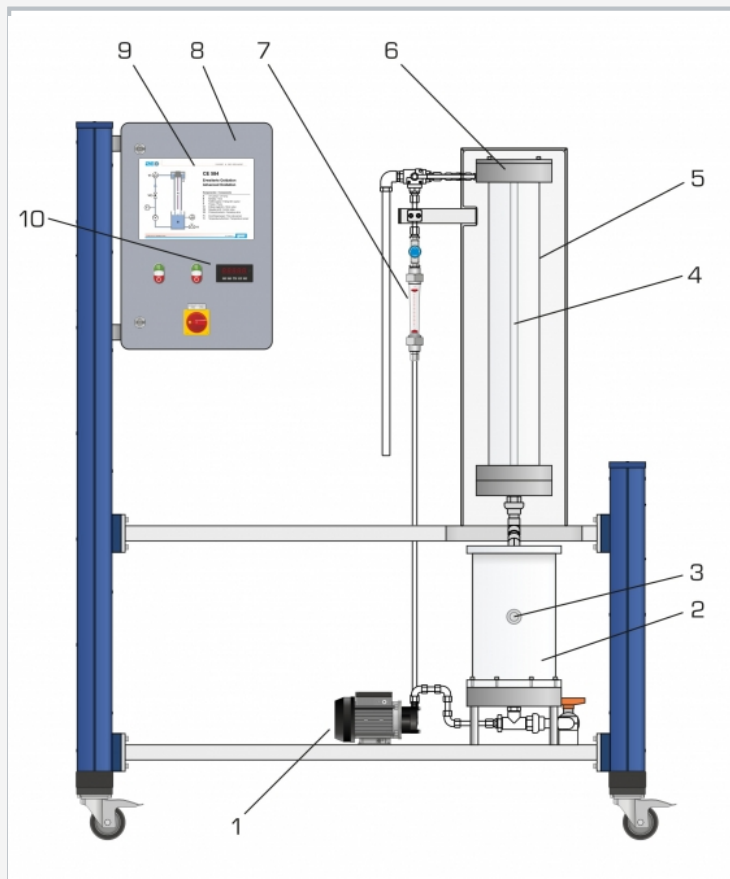

1 pump, 2 tank, 3 temperature sensor, 4 UV lamp with protective tube, 5 falling film reactor (tube), 6 channel, 7 flow meter, 8 switch cabinet, 9 process schematic, 10 digital temperature display

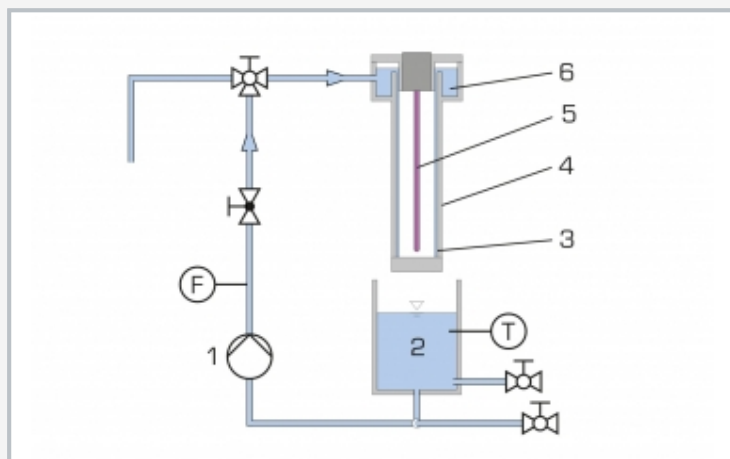

1 pump, 2 tank, 3 falling film, 4 falling film reactor (tube), 5 UV lamp, 6 channel; F flow rate, T temperature

Specification

- [1] advanced oxidation process
- [2] use of hydrogen peroxide and UV light
- [3] formation of hydroxyl radicals (OH radicals)
- [4] falling film reactor with UV lamp
- [5] discontinuous operation
- [6] flow rate adjustable
- [7] measurement of temperature and flow rate
- [8] digital temperature indication
- [9] protection device against UV radiation

Technical data

Falling film reactor (tube)

- diameter: 130mm
- height: 1000mm
- material: glass

UV lamp

- emitted wavelength: 254nm
- power: 120W

Pump

- max. flow rate: 360L/h
- max. head: 9m

Tank

- capacity: 10L

Measuring ranges

- flow rate: 30...320L/h
- temperature: 0...50°C

230V, 50Hz, 1 phase

230V, 60Hz, 1 phase; 120V, 60Hz, 1 phase

UL/CSA optional

LxWxH: 1510x790x1900mm

Weight: approx. 170kg

Required for operation

water connection, drain, hydrogen peroxide, triethylene glycol dimethyl ether (recommendation)

Scope of delivery

- 1 trainer
- 1 set of accessories
- 1 set of instructional material