

# HM 156

## Water hammer and surge chamber



The illustration shows a similar unit

### Description

- visualisation of water hammer
- operation of a surge chamber
- determining the wave propagation velocity in water
- GUNT software for displaying the water hammer and oscillations

In structures such as hydroelectric power plants, or in systems for supplying water, changes in flow rate result in pressure fluctuations. For example during startup and shutdown of hydraulic machines or by opening and closing shut-off elements. There is a distinction to be made between rapid pressure changes that propagate with high velocity (water hammer) and slow pressure changes caused by mass oscillations. Pipeline systems use air vessels or surge chambers to dampen water hammer and mass oscillations.

HM 156 is used to generate and visualise water hammer in pipes and to demonstrate how a surge chamber works. The trainer contains a pipe section with a ball valve and a surge chamber and a second pipe section with a solenoid valve.

In the first experiment a water hammer is produced by rapidly closing the ball valve. The sudden deceleration of the water mass releases kinetic energy, which is converted into potential energy in the surge chamber. The resulting pressure oscillations are measured by a pressure sensor behind the surge chamber and displayed in the software as a pressure curve. The oscillation can also be seen as pendulum movement of the water level in the surge chamber.

In the second experiment a rapid closing of the solenoid valve in the second pipe section produces a strong water hammer. The water's kinetic energy is converted into pressure energy. The water hammer and the subsequent oscillations are detected by two pressure sensors in the pipe section and displayed in the software as a pressure curve.

The water is supplied and the flow rate measured by the supply unit.

### Learning objectives/experiments

- demonstrating water hammer in pipes
- determining the wave propagation velocity in water
- understanding how a surge chamber works
- natural frequency in the surge chamber

# HM 156

## Water hammer and surge chamber

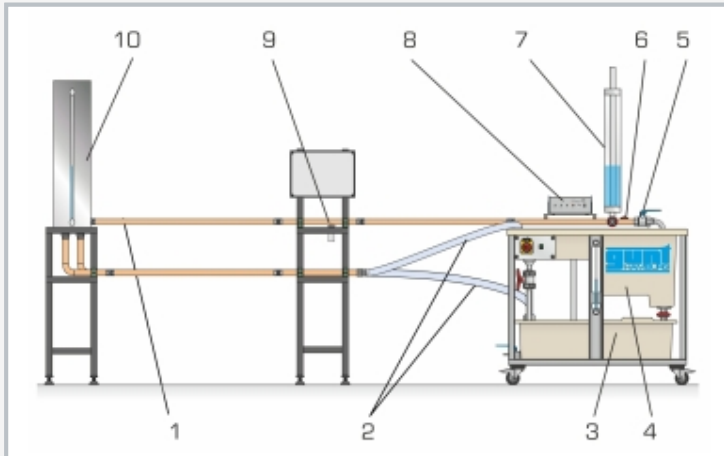

1 two parallel pipe sections, 2 water supply, 3 storage tank supply unit, 4 measuring tank supply unit, 5 ball valve/solenoid valve, 6 pressure sensor surge chamber, 7 surge chamber, 8 control unit, 9 pressure sensor in the measuring section for water hammer, 10 tank

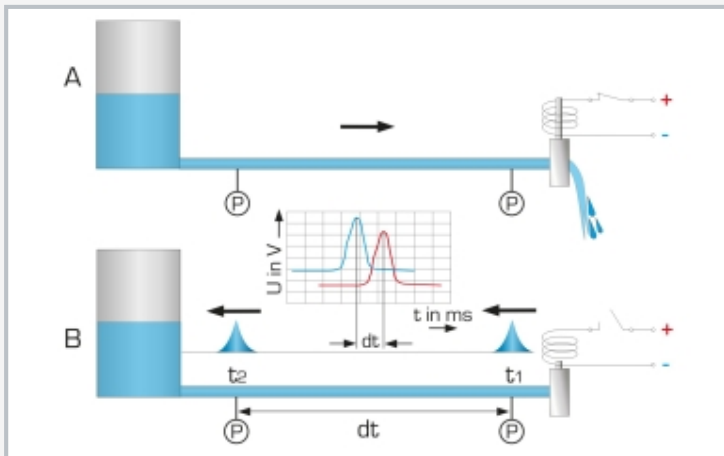

Producing a water hammer; A: solenoid valve open, B: solenoid valve closed; P pressure, t time, U voltage

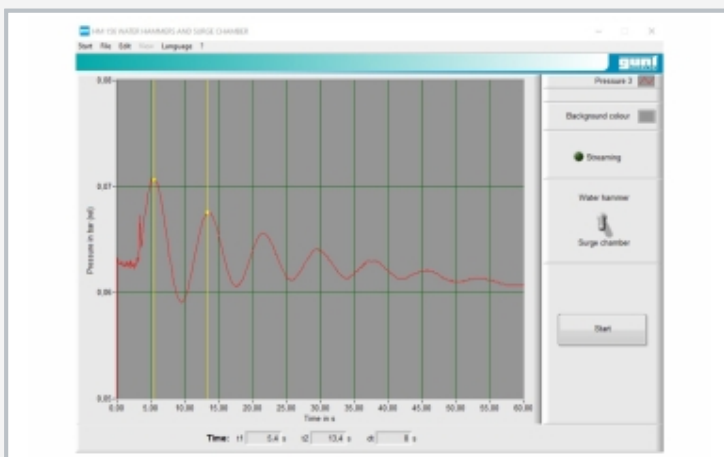

Software screenshot

### Specification

- [1] functioning of a surge chamber
- [2] pipe section with ball valve and surge chamber
- [3] surge chamber designed as transparent PMMA tank
- [4] pressure sensor behind the water chamber for measuring the pressure wave
- [5] pipe section with solenoid valve and two pressure sensors for measuring water hammer
- [6] volumetric flow measurement via measuring tank of the supply unit
- [7] representation of the pressure curves with GUNT software
- [8] GUNT software for data acquisition via USB under Windows 10

### Technical data

Pipe section for pressure oscillations

- copper
- length: 5875mm, Ø, inner: 26mm
- ball valve
- surge chamber, PMMA
  - ▶ height: 825mm
  - ▶ Ø, inner: 50mm

Pipe section for water hammer

- copper
- length: 5875mm, Ø, inner: 26mm
- distance between sensors: 3000mm
- solenoid valve, constant closing time: 20...30ms

Tank: 50L

Supply unit

- pump
  - ▶ power consumption: 250W
  - ▶ max. flow rate: 150L/min
  - ▶ max. head: 7,6m
- storage tank: 180L,
- measuring tank: 60L

Measuring ranges

- pressure: 2x 0...10bar (pipe section)
- pressure: 0...0,3bar (surge chamber)

230V, 50Hz, 1 phase

230V, 60Hz, 1 phase; 120V, 60Hz, 1 phase

UL/CSA optional

LxWxH: 6800x820x2000mm (total)

Weight: approx. 155kg

### Required for operation

PC with Windows

### Scope of delivery

- 1 trainer with supply unit
- 1 GUNT software + USB cable
- 1 set of accessories
- 1 set of instructional material