

CE 581

Water treatment plant 1



The illustration shows a similar unit: trainer (left) and supply unit (right), screen mirroring is possible on different end devices

Description

- **water treatment by depth filtration, adsorption, ion exchange**
- **plant control using an integrated PLC**
- **integrated router for operation and control via an end device and for screen mirroring on additional end devices: PC, tablet, smartphone**

Depth filtration, adsorption and ion exchange are key unit operations in water treatment. CE 581 enables these three operations to be demonstrated.

The raw water is pumped from above into a gravel filter and then routed into a sand filter. In the process, suspended solids are removed from the raw water. The filtered water then flows into the second treatment stage. There dissolved substances are removed by adsorption on aluminium oxide and on activated carbon. Then the water passes on to the third treatment stage. In this stage unwanted ions are removed from the water by ion exchange. First the water is softened by cation exchange. The water is then desalinated in a mixed bed ion exchanger containing cation and anion exchangers.

The separate supply unit includes pumps and tanks for the raw water and treated water. The raw water tank can be aerated. This ensures the raw water is mixed through. It also enables dissolved substances (such as iron) to be precipitated so as to then filter them. A connection to backwash the sand filters is provided.

The flow rate, temperature, conductivity, differential pressure and system pressure are measured. Samples can be taken at all relevant points.

The trainer is controlled by the PLC via touch screen. By means of an integrated router, the trainer can alternatively be operated and controlled via an end device. The user interface can also be displayed on additional end devices (screen mirroring). Via the PLC, the measured values can be stored internally. Access to stored measured values is possible from end devices via WLAN with integrated router/LAN connection to the customer's own network. Via direct LAN connection the measured values can also be transmitted to a PC where they can be analysed using the GUNT software.

Learning objectives/experiments

- learning the fundamental principle of the unit operations depth filtration, adsorption and ion exchange
- observation and determination of the pressure loss in depth filtration
- plotting of breakthrough curves (adsorption)
- comparison of various adsorption materials
- familiarisation with the fundamental principle of ion exchange
- screen mirroring: mirroring of the user interface on end devices
 - ▶ menu navigation independent of the user interface shown on the touch screen
 - ▶ different user levels available on the end device: for observing the experiments or for operation and control

CE 581

Water treatment plant 1

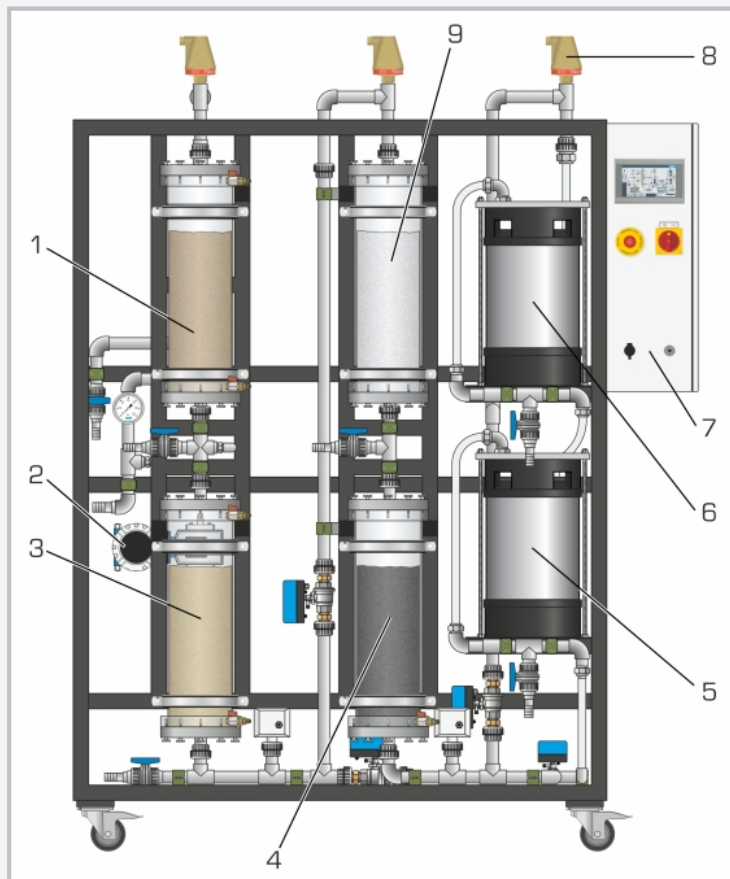

1 gravel filter, 2 electromagnetic flow rate sensor, 3 sand filter, 4 adsorber (activated carbon), 5 cation exchanger, 6 mixed bed ion exchanger, 7 switch cabinet, 8 bleed valve, 9 adsorber (aluminium oxide)

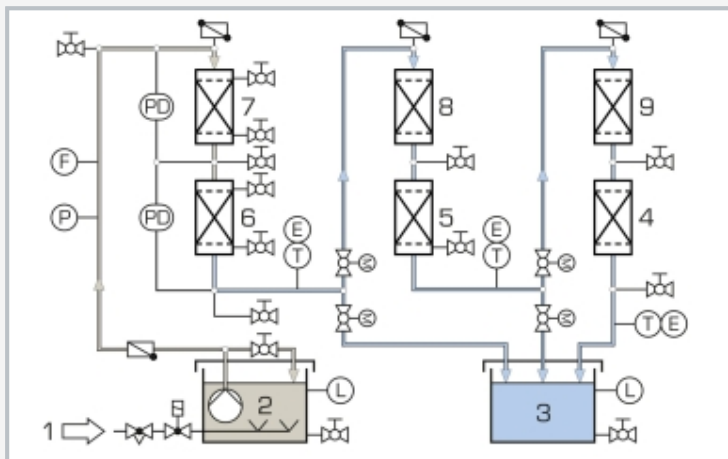

1 external compressed air supply, 2 raw water, 3 treated water, 4 mixed bed ion exchanger, 5 adsorber (activated carbon), 6 sand filter, 7 gravel filter, 8 adsorber (aluminium oxide), 9 cation exchanger; E conductivity, F flow rate, L level, P system pressure, PD differential pressure, T temperature

Specification

- [1] 3 unit operations in water treatment: depth filtration, adsorption, ion exchange
- [2] gravel filter, sand filter, aluminium oxide adsorber, activated carbon adsorber, cation exchanger, mixed bed ion exchanger
- [3] separate supply unit with tanks for raw water and treated water
- [4] raw water tank with possibility of aeration
- [5] gravel filter and sand filter with differential pressure measurement
- [6] flow rate measurement of raw water
- [7] measurement of conductivity and temperature after each treatment stage
- [8] PLC with touch screen for control of the plant
- [9] integrated router for operation and control via an end device and for screen mirroring: mirroring of the user interface on up to 5 end devices
- [10] data acquisition via PLC on internal memory, access to stored measured values via WLAN with integrated router/ LAN connection to customer's own network
- [11] GUNT software for data acquisition via LAN under Windows 10

Technical data

PLC: Eaton XV-303

Raw water pump: max. flow rate: 21m³/h, max. head: 18m

Gravel filter, sand filter and adsorbers

- Ø inner: each 150mm, height: each 650mm

Ion exchanger tank

- Ø: each 240mm; height: each 410mm

Tanks for raw water and treated water

- capacity: each approx. 180L

Measuring ranges

- flow rate: 0...1300L/h

- pressure: 0...4bar

- differential pressure: 0...2,5bar

- conductivity: 0...1000µS/cm

- temperature: 0...100°C

230V, 50Hz, 1 phase; 230V, 60Hz, 1 phase

230V, 60Hz, 3 phases; UL/CSA optional

LxWxH: 1300x800x950mm (supply unit)

LxWxH: 1680x800x2140mm (trainer)

Total weight: approx. 330kg

Required for operation

water connection, drain, compressed air (min. 1bar), substances for preparation of the raw water
PC with Windows recommended

Scope of delivery

trainer, supply unit, packing unit of sand, packing unit of gravel, packing unit of aluminium oxide, packing unit of activated carbon, set of hoses, GUNT software, set of instructional material