

# HM 150.18

## Osborne Reynolds experiment



### Learning objectives/experiments

- visualisation of laminar flow
- visualisation of the transition zone
- visualisation of turbulent flow
- determination of the critical Reynolds number

### Description

- visualisation of laminar and turbulent flow
- determining the critical Reynolds number
- traditional experiment based on the model of the British physicist Osborne Reynolds

The Osborne Reynolds experiment is used to display laminar and turbulent flows. During the experiment it is possible to observe the transition from laminar to turbulent flow after a limiting velocity. The Reynolds number is used to assess whether a flow is laminar or turbulent.

With HM 150.18 the streamlines during laminar or turbulent flow are displayed in colour with the aid of an injected contrast medium (ink). The experimental results can be used to determine the critical Reynolds number.

The experimental unit consists of a transparent pipe section through which water flows, with flow-optimised inlet. A valve can be used to adjust the flow rate in the pipe section. Ink is injected into the flowing water. A layer of glass beads in the water tank ensures an even and low-turbulence flow.

The experimental unit is positioned easily and securely on the work surface of the HM 150 base module. The water is supplied and the flow rate measured by HM 150. Alternatively, the experimental unit can be operated by the laboratory supply.

# HM 150.18

## Osborne Reynolds experiment

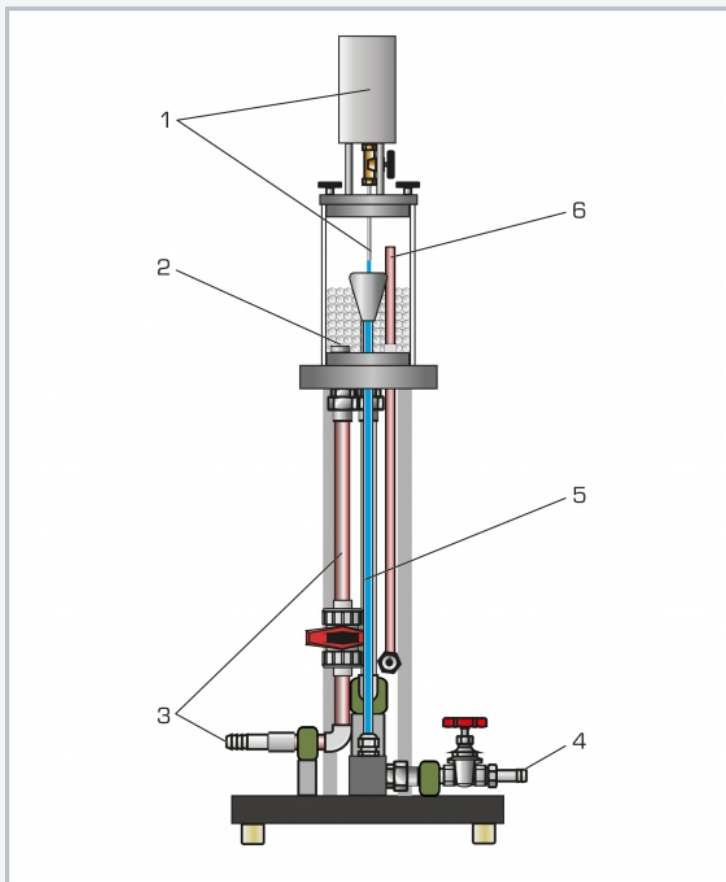

1 tank for ink with inlet pipe, 2 overflow, 3 water supply, 4 water drain, 5 pipe section with valve, 6 water tank with glass beads



Flow conditions from left to right: laminar flow, transition from laminar to turbulent flow, turbulent flow

### Specification

- [1] visualisation of laminar and turbulent flow in the Osborne Reynolds experiment
- [2] water as flowing medium and ink as contrast medium
- [3] vertical glass pipe section
- [4] water tank with glass beads to stabilise the flow
- [5] flow rate in the pipe section can be adjusted via a valve
- [6] flow rate determined by HM 150 base module
- [7] water supply using HM 150 base module or via laboratory supply

### Technical data

#### Water tank

- capacity: 2200mL

#### Pipe section

- length: 675mm
- $\varnothing$ , inner: 10mm

#### Tank for ink

- capacity: approx. 250mL

LxWxH: 400x400x1140mm

Weight: approx. 16kg

### Required for operation

HM 150 (closed water circuit) or water connection, drain

### Scope of delivery

- 1 experimental unit
- 1 bag of glass beads
- 1 ink (1L)
- 1 set of instructional material

# HM 150.18

## Osborne Reynolds experiment

Optional accessories

070.15000

HM 150

Base module for experiments in fluid mechanics