

HM 150.16

Series and parallel configuration of pumps



Description

- **series and parallel configuration of pumps**
- **determining pump characteristic curves**

In complex systems, pumps can be connected in series or in parallel. In series operation the heads are added together and in parallel operation, the flow rates of the pumps are added. Series and parallel configuration of pumps behave similar to series and parallel configuration of electric resistances in electric circuits. The pump correlates with the electric resistance, the flow correlates with the electric current and the head with the voltage.

With HM 150.16 pumps are studied individually, in series and in parallel configuration.

The experimental unit contains two identical centrifugal pumps and an intake tank with overflow. The overflow ensures a constant suction head in the tank, regardless of the water supply. Ball valves in the pipes allow easy switching between series and parallel operation.

Pressures at inlet and outlet of the two pumps are displayed on manometers.

The experimental unit is positioned easily and securely on the work surface of the HM 150 base module. The water is supplied and the flow rate measured by HM 150. Alternatively, the experimental unit can be operated by the laboratory supply.

Learning objectives/experiments

- investigation of pumps in series and parallel configuration
 - ▶ determining the head
 - ▶ recording the pump characteristics
 - ▶ determining the hydraulic power
 - ▶ determining the operating point

HM 150.16

Series and parallel configuration of pumps



1 tank, 2 overflow, 3 water connection, 4 ball valve, 5 pump, 6 pump switch, 7 drain, 8 manometer

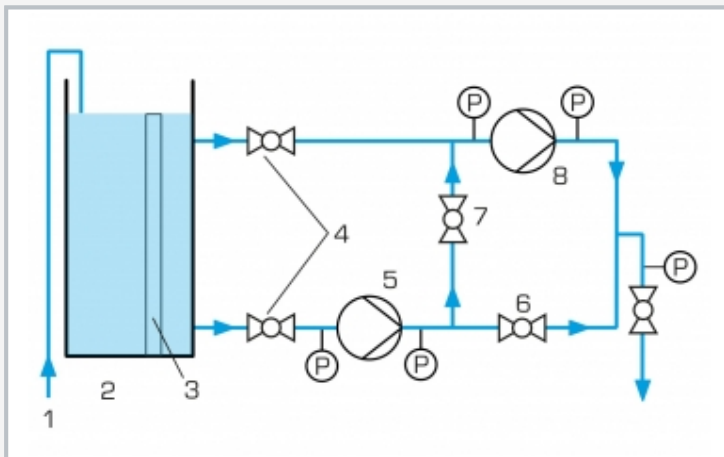

1 water connection, 2 tank, 3 overflow, 4 ball valve, 5 pump 1, 6 and 7 ball valves for switching the pumps between series and parallel operation, 8 pump 2; P pressure

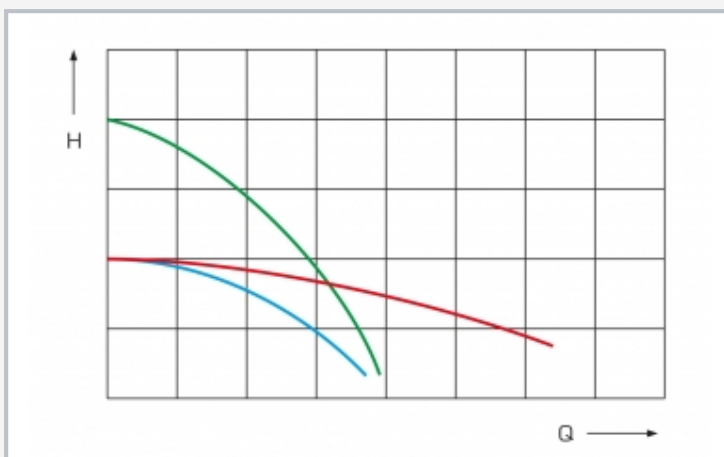

Characteristic curves: blue: one pump in operation, red: parallel configuration of pumps, green: series configuration of pumps; H head, Q flow rate

Specification

- [1] investigation of series and parallel configuration of pumps
- [2] two identical centrifugal pumps
- [3] transparent tank as intake tank
- [4] overflow in the tank ensures constant suction head
- [5] ball valves used to switch between series and parallel operation
- [6] manometers at inlet and outlet of each pump
- [7] flow rate determined by base module HM 150
- [8] water supply via HM 150 or via laboratory supply

Technical data

- 2x centrifugal pump
- power consumption: 370W
- max. flow rate: 21L/min
- max. head: 12m

Tank: 13L
Pipes and pipe connections: PVC

Measuring ranges

- pressure (inlet): 2x -1...1,5bar
- pressure (outlet): 3x 0...2,5bar

230V, 50Hz, 1 phase
230V, 60Hz, 1 phase; 120V, 60Hz, 1 phase
UL/CSA optional
LxWxH: 1110x650x500mm
Weight: approx. 62kg

Required for operation

HM 150 (closed water circuit) or water connection, drain

Scope of delivery

- 1 experimental unit
- 1 set of instructional material

HM 150.16

Series and parallel configuration of pumps

Optional accessories

070.15000 HM 150 Base module for experiments in fluid mechanics