

# HM 124

## Fluid mechanics experimental plant



### Description

- large scale to ensure realistic measuring results
- operating behaviour of centrifugal pumps
- pressure losses in piping elements
- $K_v$  value determination of control valves
- flow rate and pressure control

HM 124 allows precise investigations of different fluidic problems. The large scale of the experimental plant and the use of industrial components deliver results close to reality. The dimensions of the experimental plant allow sufficient inlet and outlet sections for the flow formation.

HM 124 consists of several assemblies: a pump station with two differently sized centrifugal pumps, a priming tank, two measuring sections – each of five meter length – one with a nominal diameter of 50mm (DN50), the other one with 25mm nominal diameter (DN25), and a control room consisting of a control console and data acquisition. Optionally the experimental plant may be operated with an additional tank on a lower level for higher suction heads. The complex system may be adjusted in a flexible way to the local facilities.

Many interchangeable piping elements allow an extensive experimental range. Using the measuring section DN50, the  $K_v$  values of different control valves can be determined conforming to standards, e.g. an electropneumatic control valve. A transparent pipe section with ink injection allows to observe the flow in the wake of a fitting or a valve. To measure pipe resistances, pipe sections with different surface roughness are inserted in the measuring section DN25.

A pressure controlled system controls the system pressure, the flow rate is controlled by a flow controller and the speed of the pumps. The pumps are operated by the control console. Thus the mapping of pump characteristics is comfortably done.

The experimental plant is equipped with numerous sensors for pressure, flow rate, temperature, speed and torque. The measured values can be read on digital displays. At the same time, the measured values can also be transmitted directly to a PC via USB. The data acquisition software is included.

### Learning objectives/experiments

- experiments with pumps, valves and fittings and pipe sections
- operating behaviour of centrifugal pumps in individual or parallel operation
- measurement of the NPSH value of pumps
- pressure losses in pipe sections with different surface roughness
- pressure losses in pipe fittings
- $K_v$  value determination of control valves and fittings
- visual investigation of turbulent pipe flow
- experiments on flow rate and pressure controlled systems

# HM 124

## Fluid mechanics experimental plant

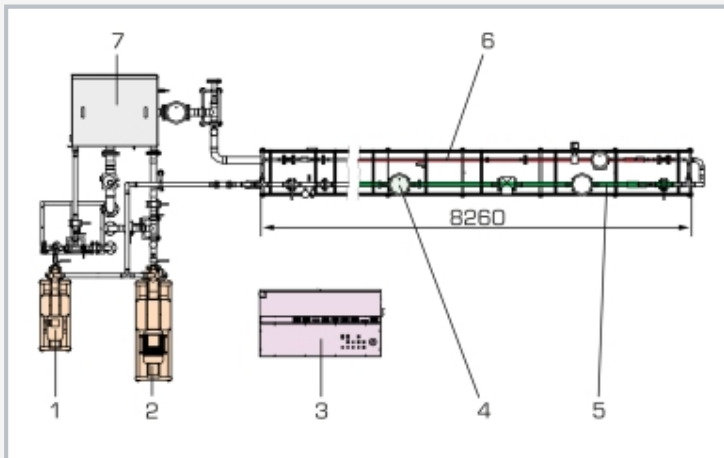

Flexible setup of the experimental plant: 1 pump 32/160, 2 pump 40/250, 3 control console, 4 measuring location for control valves, 5 measuring section DN50, 6 measuring section DN20/25, 7 upper priming tank

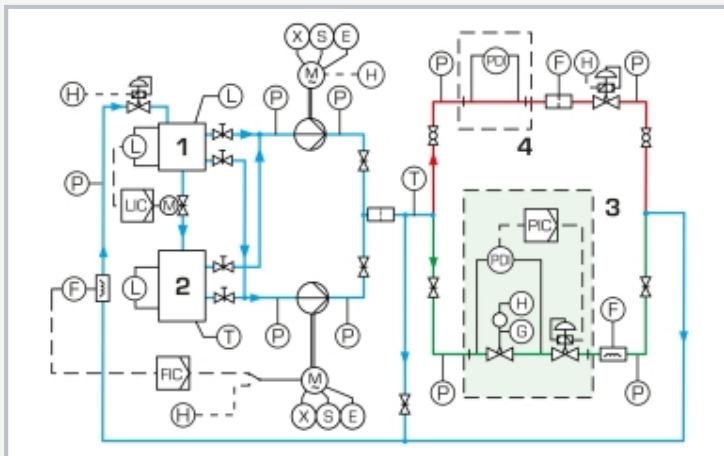

Complex process schematic: 1 upper priming tank, 2 additional tank in lower level, 3 measuring location for control valves, 4 measuring location for pipe sections; green: measuring section DN50, red: measuring section DN20/25, blue: pipes



Control station consisting of control console and data acquisition for convenient recording and analysis of the experiments

### Specification

- [1] experimental plant in laboratory scale
- [2] 2 measuring sections, each of 5m length
- [3] 2 centrifugal pumps including electrical and mechanical measurement, variable speed via frequency converter
- [4] measuring location DN50 conforming to standards to determine  $K_v$  values in control valves
- [5] interchangeable piping elements
- [6] flow controlled system
- [7] separate control station with control console and data acquisition
- [8] electronic measurement and digital display of all important measured values at the control console
- [9] differential pressure control at determination of  $K_v$  value
- [10] GUNT software for data acquisition via USB under Windows 10

### Technical data

#### Pipe system

- nominal diameters: DN25, DN50, DN80, DN100
- pressure stage: PN10
- priming tank: 500L (optional tank 1200L)
- control valves: 1x  $K_{vs}10$ , 2x  $K_{vs}40$ , 1x  $K_{vs}100$

#### Pumps, speed: 300...3000min<sup>-1</sup>

- norm pump 32/160, 20m<sup>3</sup>/h, 34,7m, 4kW
- norm pump 40/250, 40m<sup>3</sup>/h, 66,5m, 11kW

#### Pipe sections

- 1: length: 3m, smooth/rough, DN25/DN20
- 2: length: 3m, smooth, DN50
- 3: length: 1,2m, 10 measuring connections, transparent, DN50

#### Measuring ranges

- pressure: 8x 10bar, 2x -1...0,6bar
- differential pressure: 2x 0...1,6bar
- flow rate: 1x 0...50m<sup>3</sup>/h, 1x 0...100m<sup>3</sup>/h
- orifice plate flow meter: DN25, 0...0,6bar

400V, 50Hz, 3 phases

LxWxH: 11450x4500x2400mm

Weight: approx. 1000kg

### Required for operation

water connection: 1,5m<sup>3</sup>/h

PC with Windows recommended

### Scope of delivery

- 1 pump station
- 2 measuring sections
- 2 priming tanks
- 1 control console
- 1 set of accessories
- 1 GUNT software CD + USB cable
- 1 set of instructional material