

HM 122

Pressure losses in pipes

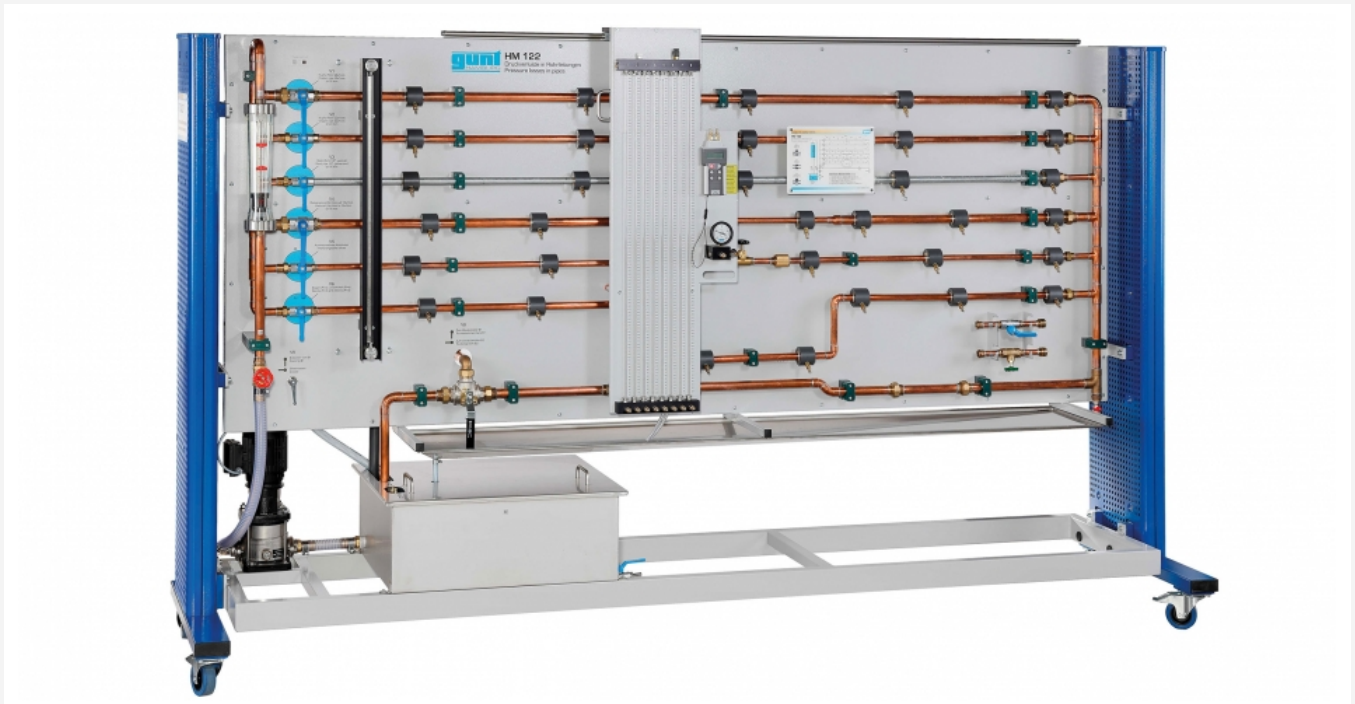

Description

- resistances and losses in turbulent pipe flow
- closed water circuit with tank and pump
- ideal measurement results through long measuring section with several pressure measuring points
- precise pressure measurement via annular chambers

Knowledge of pressure losses in various pipe elements is a key factor in designing pipe systems. The HM 122 trainer allows the determination by experiment of these important coefficients and the investigation of the pressure curve in typical pipe sections.

The trainer comprises three straight pipe sections made of different materials and with different diameters. Also included are: a pipe section with pipe bends, a pipe section with contraction and enlargement and a pipe section with interchangeable valves and fittings.

The large length of the pipe sections of 2,5m and the fact each section is fitted with at least five pressure measuring points means it is possible to obtain very accurate measurements and demonstrate the linear reduction in pressure in a pipe.

A rotameter and a volumetric measuring tank are included for comparison measurements and calibrations. The volumetric measurement using a stopwatch gives highly accurate results even at low flow rates. Tube manometers, a Bourdon tube pressure gauge and a differential pressure sensor are provided for pressure and differential pressure measurements.

The pressure measuring points are designed as annular chambers for accurate pressure measurement. A movable manometer panel saves space and allows for optimal accessibility. The trainer includes a closed water circuit with tank and a two-stage centrifugal pump. This means the trainer can be used independent of the laboratory network.

Learning objectives/experiments

- fundamentals of flow measurement
- fundamentals of pressure measurement
- determination of the friction factor for different pipe materials and diameters
- resistance coefficients of pipe bends, enlargements and contractions
- pressure losses and opening characteristics of valves and fittings

HM 122

Pressure losses in pipes

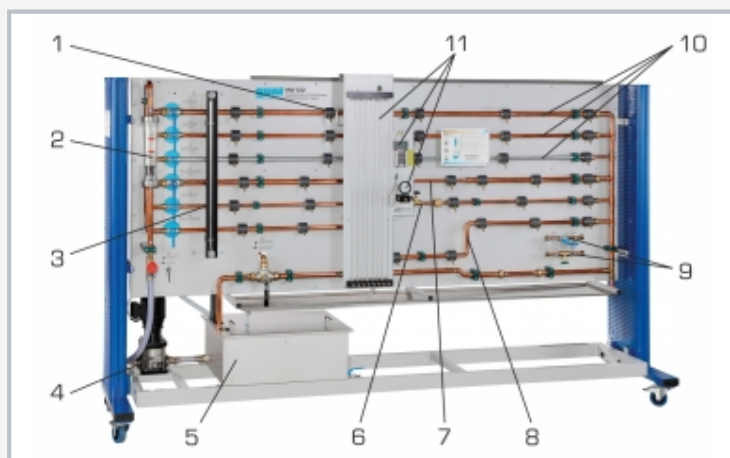

1 annular chamber for pressure measurement, 2 rotameter, 3 measuring tank level indicator, 4 pump, 5 tank, 6 pipe section with interchangeable valves and fittings, 7 pipe section with contraction and enlargement, 8 pipe section with pipe bends, 9 interchangeable valves and fittings, 10 long pipe section, 11 movable panel with Bourdon tube pressure gauge, differential pressure sensor and tube manometer

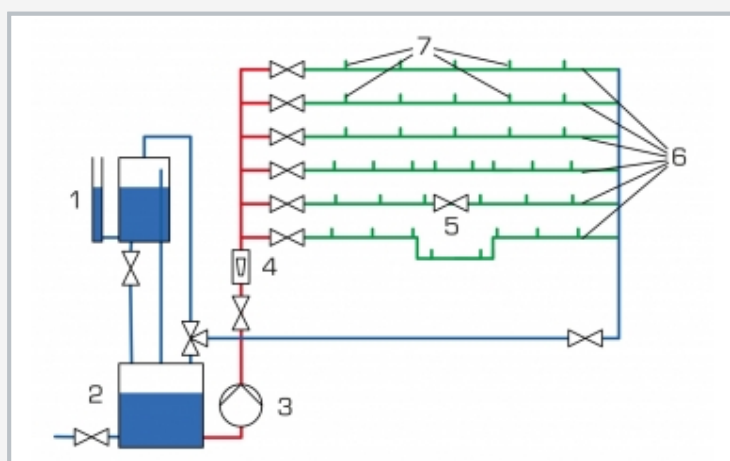

1 volumetric measuring tank, 2 supply tank, 3 centrifugal pump, 4 rotameter, 5 interchangeable valves and fittings, 6 different pipe sections, 7 pressure measuring points

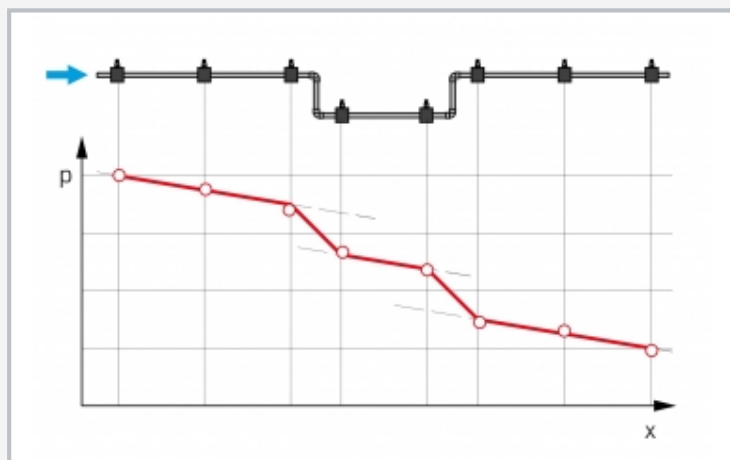

Pressure curve in the pipe section with 4 pipe bends (top); x position in the pipe section, p water pressure

Specification

- [1] investigation of pressure losses
- [2] three long pipe sections made of copper and steel with different diameters
- [3] pipe section with pipe bends
- [4] pipe section with sudden contraction and enlargement
- [5] pipe section with interchangeable fittings with different opening characteristics: needle valve, shut-off valve, ball valve
- [6] determination of the pressure curve along the measuring section with up to 8 pressure measuring points
- [7] easy pressure measurement via annular chambers
- [8] pressure and differential pressure measurement with 8 tube manometers, Bourdon tube pressure gauge and electronic differential pressure sensor
- [9] flow measurement via rotameter and volumetric measuring tank
- [10] closed water circuit with tank and two-stage centrifugal pump
- [11] stainless steel tank

Technical data

- 2-stage centrifugal pump
 - power consumption: 0,37kW
 - max. flow rate: 4,5m³/h
 - max. head: 14,7m

3 straight pipe sections, measuring length: 2,5m

- copper, diameter: 28x1mm, 22x1mm
- steel, diameter: 1/2"

Pipe section with pipe bend

- copper, diameter: 22x1mm

Pipe section with contraction/enlargement

- copper
- contraction, diameter: 18x1mm
- enlargement, diameter: 28x1mm

Pipe section with valves and fittings

- copper, diameter: 18x1mm

Volumetric measuring tank: 20L

Tank for water: 110L

Measuring ranges

- pressure: -1...1,5bar
- differential pressure: 1x 0...+/-350mbar, 8x 0...1000mmWC
- flow rate: 1x 400...4000L/h

230V, 50Hz, 1 phase

230V, 60Hz, 1 phase; 120V, 60Hz, 1 phase

UL/CSA optional

LxWxH: 3260x790x1930mm

Weight: approx. 340kg

Scope of delivery

- 1 trainer
- 1 set of instructional material