

HM 111

Pipe networks



Description

- structure of various pipe networks
- pressure losses at various piping elements and pipe networks
- closed water circuit with tank and pump

An important task in the construction of pipelines is to determine the pressure and flow rate in complex piping systems. In practice, the calculation of the total pressure losses serves as a foundation for the design of suitable drive units for heating and air conditioning systems, drinking water supply systems and parts of wastewater systems. Knowledge of pressure losses is also used to optimise operation.

HM 111 enables the construction and investigation of various pipe networks, such as parallel and series connections of pipes, their branching and merging, and the study of individual pipes. In analogy to Kirchhoff's laws of electricity, it is possible to conduct nodal analysis.

The five pre-installed pipe sections on the top of the trainer are connected to pipe networks using the piping elements. Tank, pipes, piping elements and valves are made entirely of plastic. The individual pipe sections are shut off by ball valves. During the experiments, the pressure losses in various pipes and piping elements are recorded and evaluated.

Two manometers for different measuring ranges are included to measure differential pressure. The flow rate is measured volumetrically.

The trainer has its own water supply. The closed water circuit includes a supply tank with submersible pump.

Learning objectives/experiments

- recording the calibration curve for pipe sections: pressure loss over flow rate
- pipe sections connected in parallel
- pipe sections connected in series
- combined series and parallel connection
- investigation of a closed circular pipeline
- differential pressure measurement
- pressure losses at various piping elements

HM 111

Pipe networks

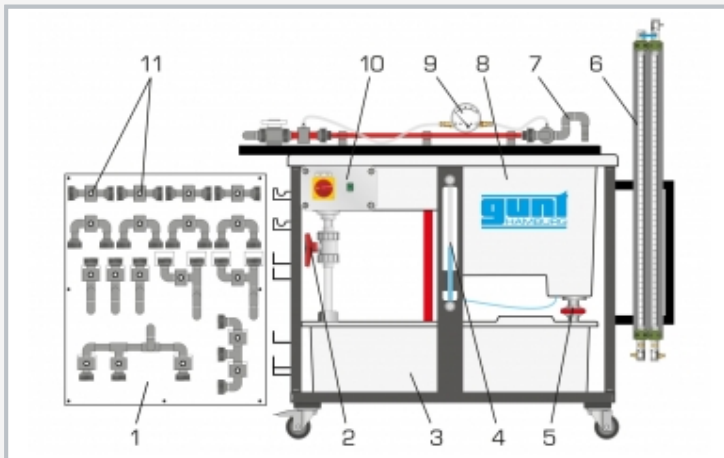

1 panel with piping elements, 2 valve for adjusting the flow rate, 3 supply tank with submersible pump, 4 measuring tank level indicator, 5 gate valve for emptying the measuring tank, 6 twin tube manometers, 7 pipe sections, 8 measuring tank, 9 differential pressure manometer, 10 switch box, 11 pressure measuring point

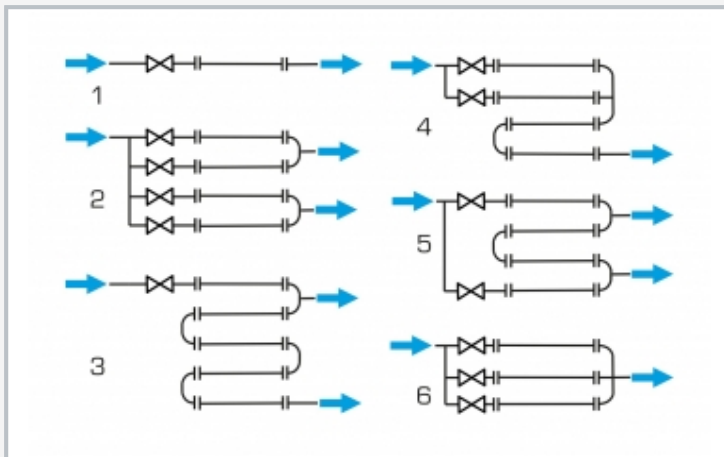

Different pipe networks constructed from pipe sections: 1 calibration of pipe sections, 2 doubling, 3 series connection, 4 parallel and series connection, 5 closed circular pipeline, 6 parallel connection

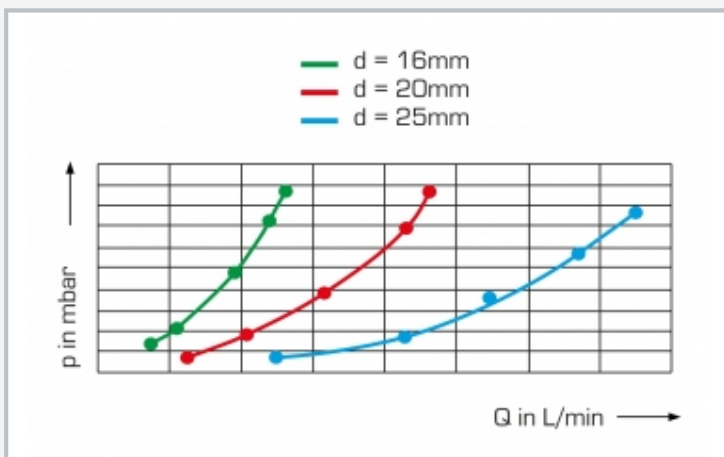

The diagram shows the pressure loss over flow rate for different pipe diameters: p pressure, Q flow rate, d inner diameter

Specification

- [1] investigation of different pipe networks
- [2] five pre-installed pipe sections with different diameters
- [3] panel for piping elements
- [4] construction of pipe networks from pipe sections and various piping elements
- [5] calibration of pipe sections
- [6] parallel and series connection of pipe sections
- [7] construction of a closed circular pipeline
- [8] differential pressure measurement with twin tube manometers and differential pressure manometer
- [9] flow rate measurement with measuring tank (can be shut off), stopwatch and level indicator

Technical data

Pump

- power consumption: 250W
- max. flow rate: 9m³/h
- max. head: 7,6m

Pipe network, max. flow rate: 4,8m³/h

Pipe sections, length 700mm each

- 1x Ø 25x1,9mm
- 2x Ø 20x1,5mm
- 2x Ø 16x1,2mm

Tank for water: 180L

Tank for flow rate measurement

- small measuring range: 10L
- large measuring range: 40L

Stopwatch: 1/100s

Measuring ranges

- differential pressure:
 - ▶ 1x 0...1bar
 - ▶ 1x 0...100mbar

230V, 50Hz, 1 phase

230V, 60Hz, 1 phase; 120V, 60Hz, 1 phase

UL/CSA optional

LxWxH: 1550x800x1600mm

Weight: approx. 117kg

Scope of delivery

- 1 trainer
- 1 stopwatch
- 1 set of instructional material