

HL 710

Air duct systems



Description

- **planning and setup of simple and complex air duct systems**
- **measurement of the dynamic and static pressures in air duct systems**
- **measurement of the air velocity and volumetric flow rate under different conditions**

Ventilation systems are used in many areas. They are used to ventilate offices, sports halls, production halls, conference halls etc. These systems consist of an air duct system and often other facilities for the conditioning of room air. There may also be elements for air purification or sound insulation, e.g. filters.

The trainer HL 710 examines how the air can be distributed in a building. The air duct system is supplied via a speed-controlled fan. The trainee constructs variable air duct systems from commercial components, such as pipes, pipe bends, branches, filters and disk valves. Connections for pressure measurements can be installed at any position.

The effects of the individual components on the pressure loss and thus on the velocity and flow rate of the air are examined. For this purpose there are two manometers with different measuring ranges and a manual device for measuring the air velocity. The fan characteristic is also determined and the power consumption of the fan is measured.

Learning objectives/experiments

- plan, setup and test air duct systems
- typical components of ventilation technology
- measure the flow rate and velocity of the air
- measure dynamic and static pressures
- determination of the pressure loss via different components: pipe bends, angles, distributors etc.
- recording of system characteristics
- recording of the fan characteristic
- determination of the operating point
- calculate the electric capacity of the fan motor with regard to current and voltage
- calculate the fan efficiency

HL 710

Air duct systems

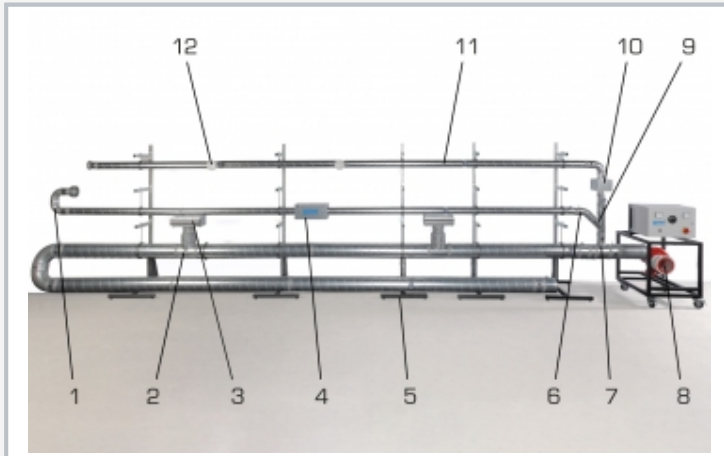

1 90° pipe bend, 2 reducer, 3 slotted outlet, 4 pocket filter, 5 assembly stand, 6 45° pipe bend, 7 T piece, 8 fan, 9 branch, 10 filter cartridge, 11 iris diaphragm, 12 disk valve

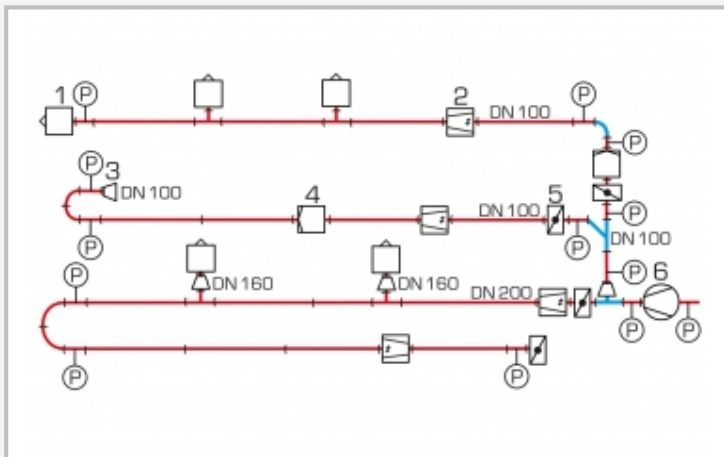

Pipe routing diagram: 1 inlet air or disk valve, 2 iris diaphragm, 3 reducer, 4 filter, 5 throttle valve, 6 fan; P pressure measuring point; blue: pipe bends and joints



1 fan speed adjustment, 2 fan on/off switch, 3 main switch, 4 power meter

Specification

- [1] experimental setup for training in ventilation engineering
- [2] radial fan, on mobile frame, to connect air ducts
- [3] air ducts from galvanised folded spiral-seam pipe with pipe bends, joints and components
- [4] pressure measuring connections with variable locations
- [5] 6 assembly stands to attach the air ducts
- [6] inclined tube manometer and digital manometer for 2 different measuring ranges
- [7] measuring of the air velocity by anemometer
- [8] switch cabinet with display of power consumption

Technical data

Fan

- power consumption: 900W
- max. volumetric flow rate: 1680m³/h
- max. pressure difference: 1000Pa
- speed: 0...2840min⁻¹

Pipes

- length: 800mm, 1600mm
- diameter: 8x DN200, 8x DN100

Pipe bends and connections, each DN100 and DN200

- 90° pipe bend, 45° pipe bend
- 45° branch
- T piece, T piece with reducer
- reducer, plug-in connection, pipe coupling

Flow restriction elements, each DN100 and DN200

- throttle valve
- iris diaphragm

Filters, each DN100 and DN200

- pocket filter
- filter cartridge

Measuring ranges

- pressure: 0...200Pa / 0...2000Pa
- velocity: 0,25...30m/s
- power: 0...5,75kW

230V, 50Hz, 1 phase

230V, 60Hz, 1 phase; 120V, 60Hz, 1 phase

UL/CSA optional

LxWxH: 10000x1200x2000mm

LxWxH: 800x810x1250mm (fan)

Total weight: approx. 180kg

Scope of delivery

- 1 radial fan on mobile frame
- 6 assembly stands
- 1 set of pipes, pipe bends, connections, components (outlets, filters etc.)
- 1 inclined tube manometer
- 1 digital manometer
- 1 anemometer
- 1 set of instructional material