

HL 510

Domestic gas supply training panel



Learning objectives/experiments

- simulation of different leaks
- demonstration of leak detection
- working on gas pipes
- testing before and after gas connection in accordance with regulations

Description

- exercises on gas pipes
- simulation of leaks in pipes

The experiments are performed with air. A compressed air connection with reservoir and pressure reducing valve are included on the panel.

The trainer has two pipe circuits that can be individually selected. Various leaks can be simulated in one gas line. The other line represents a normal gas supply pipe. A gas meter is fitted in each line. Typical industrial components are used.

Leak detection and installation work can be performed on gas pipes by the trainee.

HL 510

Domestic gas supply training panel

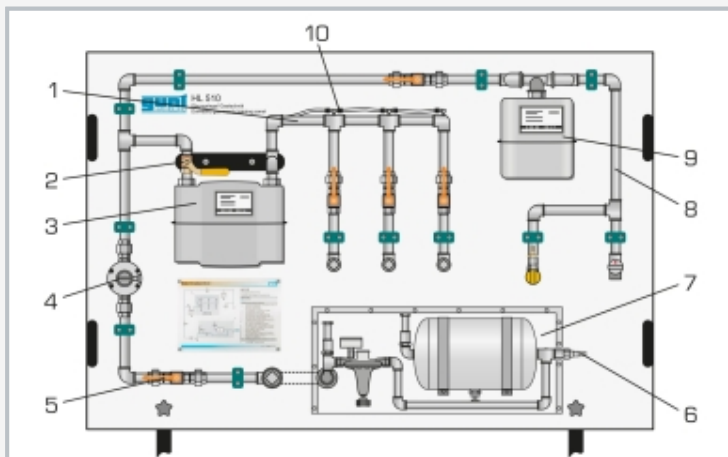

1 pipe section leak simulation, 2 ball valve, 3 gas meter with 2 connections, 4 gas pressure controller, 5 ball valve, 6 compressed air connection, 7 compressed air supply, 8 pipe section with gas socket and gas connection with ball valve, 9 gas meter with 1 connection, 10 valve

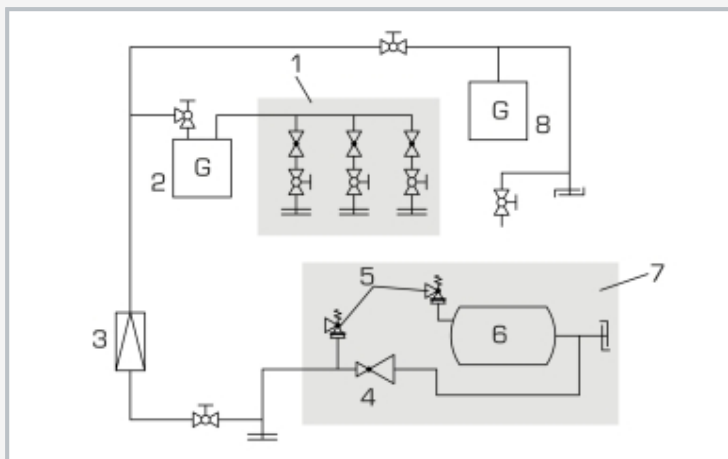

Process schematic: 1 leak simulation, 2 gas meter, 3 gas pressure controller, 4 air pressure controller, 5 safety valve, 6 pressure tank, 7 compressed air supply, 8 gas meter

Specification

- [1] Exercises on gas pipes
- [2] 2 individually selectable pipe sections
- [3] 1 gas meter with 1 connection
- [4] 1 gas meter with 2 connections
- [5] 1 pipe section for finding leaks
- [6] 1 pipe section as supply pipe with gas socket and gas connection with ball valve

Technical data

Air pressure controller

- max. inlet pressure: 10bar
- outlet pressure: 0.01...0.6bar

Gas pressure controller

- admission pressure: 350mbar
- outlet pressure: 20mbar

Leak testing device: max. 500mmWC

LxWxH: 1650x700x1850mm

Weight: approx. 125kg

Required for operation

Compressed air supply

Scope of delivery

- 1 trainer
- 1 leak testing device for gas pipes with extension
- 1 gas leak detecting spray
- 1 manual