

HL 500

Instantaneous gas heater



Learning objectives/experiments

- gas burner adjustment by volumetric method
- nozzle pressure method for gas burner adjustment
- fault finding

Description

- **methods of gas burner adjustment**
- **simulation of twelve faults**

The housing and heat exchanger of the instantaneous heater have been removed to clearly show the internal components. For safety reasons, the trainer is operated with air. Burner flames are simulated using an array of LEDs.

A diaphragm pump with pressure regulator generates the compressed air required for operation at the correct admission pressure. All the necessary safety functions such as lighting the pilot, thermocouple flame safeguard and temperature cut-out are simulated electronically using a PLC.

The PLC is programmed to simulate a total of twelve different faults.

HL 500

Instantaneous gas heater



1 gas pressure, 2 water pressure inlet, 3 rotameter for gas, 4 U-tube manometer for differential pressure measurement, 5 instantaneous gas heater, 6 main valve gas, 7 mixer, 8 system faults, 9 rotameter for water, 10 water pressure outlet

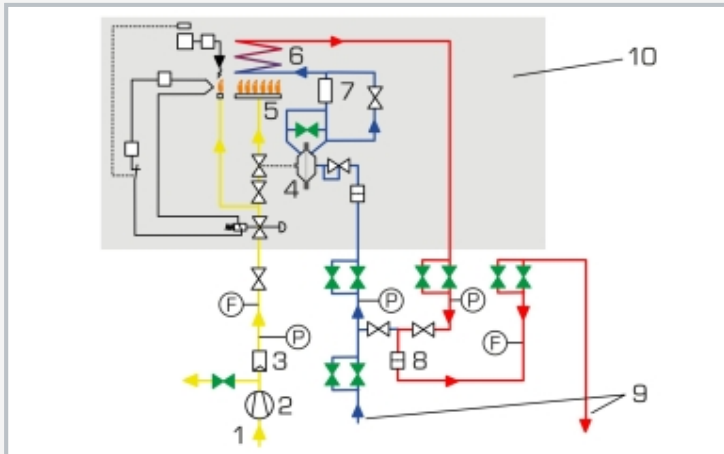

process schematic: 1 gas inlet, 2 diaphragm pump, 3 gas pressure controller, 4 gas quantity controller, 5 burner, 6 heat exchanger, 7 venturi nozzle, 8 mixer, 9 water inlet and outlet, 10 instantaneous gas heater

Specification

- [1] simulation of an instantaneous gas heater
- [2] safe operation of heater using air
- [3] diaphragm pump for pressure generation
- [4] PLC simulation of safety functions
- [5] simulation of 12 faults by PLC

Technical data

Instantaneous heater

- nominal thermal output: 19,2kW

Diaphragm pump

- max. flow rate: 70L/min

Gas pressure controller: 16...28mbar

Measuring ranges

- pressure:
 - ▶ 0...6bar (water)
 - ▶ 0...60mbar (gas)
- differential pressure: 10-0-10mbar
- flow rate:
 - ▶ 0,75...7Nm³/h (gas)
 - ▶ 75...1000L/h (water)

230V, 50Hz, 1 phase

120V, 60Hz, 1 phase

230V, 60Hz, 1 phase

UL/CSA optional

LxWxH: 1650x800x1850mm

Weight: approx. 100kg

Required for operation

water connection, drain

Scope of delivery

- 1 trainer
- 1 set of hoses
- 1 manual