

# HL 320.08

## Fan heater / air heat exchanger



### Description

- **trainer for the HL 320 “solar thermal energy and heat pump” modular system**
- **use as a heat source or heat sink**
- **axial fan with two speed settings**

Trainer consisting of a fan convactor with piping, quick-release couplings and temperature sensors. The trainer may be used both to heat rooms and to absorb ambient heat from the outside air. It can thus be operated as either a heat sink or a heat source for a heat pump.

In the case of heating rooms, compared to traditional heating radiators, fan heaters offer the possibility of achieving a comparatively good transfer of heat to the room air, even at small dimensions. This advantage makes it possible to operate room heating with lower temperatures in the heating circuit. When combined with a heat pump, the fan heater therefore often represents a beneficial application both economically and in terms of energy, especially when renovating heating systems in old buildings.

When absorbing ambient heat to supply heat to a heat pump, air heat exchangers are often used when there is no access or difficulty accessing other heat sources such as groundwater or geothermal heat collectors. The disadvantage of the energy balance, particularly unfavourable in winter, in this case is contrasted with the advantage of lower initial investment costs.

Carefully structured instructional materials have been created for the recommended modular combinations with the HL 320.08 module. As part of the documentation for the HL 320 modular system, these materials set out the basic principles and provide a step-by-step guide through the experiments.

### Learning objectives/experiments

- use of a fan convactor for heating and cooling rooms
- how the temperature difference between the heating feed and return affects the overall efficiency of a heating system
- operating conditions when used as an air heat exchanger in a heat pump system
- comparison of an air heat exchanger with other heat sources in a heat pump system

# HL 320.08

## Fan heater / air heat exchanger

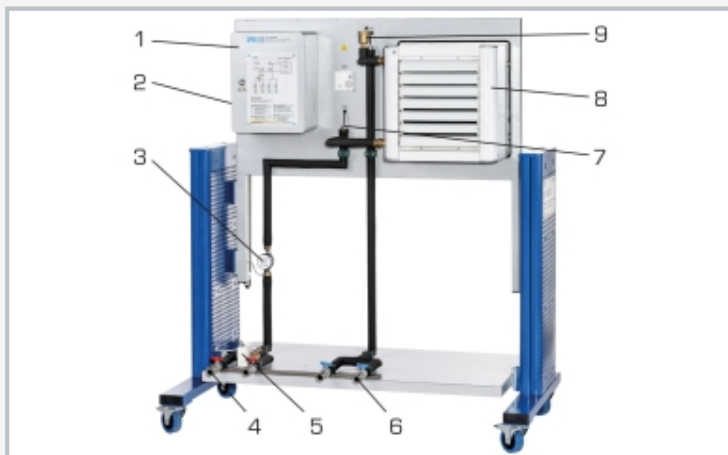

1 junction box, 2 CAN-bus connecting sockets, 3 flow meter, 4 feed flow, 5 3-way mixing valve, 6 return flow, 7 temperature sensor feed flow, 8 fan convector, 9 vent valve

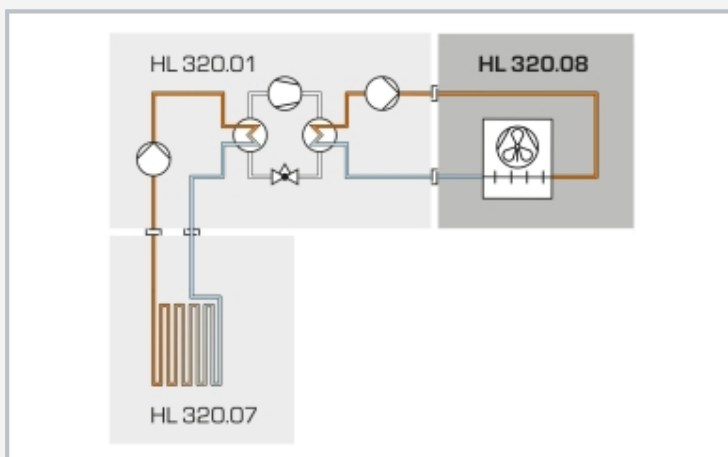

Inclusion of HL 320.08 in one possible configuration of the HL 320 modular system

	1	2	3	4	5
HL 320.01			X	X	X
HL 320.02		X			X
HL 320.03	X	X		X	X
HL 320.04	(X)	(X)		(X)	(X)
HL 320.05	X	X		X	X
HL 320.07		X	X	X	X
HL 320.08			X	X	X

Recommended combinations of the HL 320 modular system

### Specification

- [1] fan convector for connection to the HL 320 modular system
- [2] axial fan with two selectable speed settings
- [3] control by means of other controllers in the HL 320 system (CAN bus)
- [4] temperature sensors for feed and return
- [5] quick-release couplings with shut-off valves for connecting the pipes

### Technical data

#### Fan

- speed: 900/1400min<sup>-1</sup>
- flow rate: 683/1155m<sup>3</sup>h<sup>-1</sup>

#### Heat exchanger

- nominal cooling capacity: 2kW
- max. operating pressure: 10bar

#### Measuring ranges

- temperature:
  - ▶ 3x -50°C...180°C
- flow rate: 20...2500L/h

230V, 50Hz, 1 phase  
 230V, 60Hz, 1 phase  
 LxWxH: 1500x 800x1500mm  
 Weight: approx. 95kg

### Scope of delivery

- 1 trainer
- 1 manual

# HL 320.08

## Fan heater / air heat exchanger

### Required accessories

#### Combination 3

065.32001	HL 320.01	Heat pump
065.32007	HL 320.07	Underfloor heating / geothermal energy absorber

#### Combination 4

065.32001	HL 320.01	Heat pump
065.32003	HL 320.03	Flat collector
065.32005	HL 320.05	Central storage module with controller
065.32007	HL 320.07	Underfloor heating / geothermal energy absorber

#### Combination 5

065.32001	HL 320.01	Heat pump
065.32002	HL 320.02	Conventional heating
065.32003	HL 320.03	Flat collector
065.32005	HL 320.05	Central storage module with controller
065.32007	HL 320.07	Underfloor heating / geothermal energy absorber

### Optional accessories

#### Combination 4, 5

065.32004	HL 320.04	Evacuated tube collector
065.31301	HL 313.01	Artificial light source