

HL 113

Installation technology: losses in valves and fittings



Learning objectives/experiments

- pressure losses in valves and fittings
- measuring the pressure difference
- effect of the valve orifice shape on the pressure loss
- effect of the flow velocity
- determination of resistance coefficients
- comparison between experiment and calculation

Description

- **trainer for heating and sanitary engineering**
- **pressure losses in standard valves and fittings**

Pressure losses occur in pipe systems as a result of friction and turbulence. In practice, the use of shut-off valves and fittings causes pressure losses that need to be taken into consideration when designing pipe networks.

The HL 113 unit can be used to investigate the pressure losses of different shut-off valves and fittings. The pipe elements used are commercially standard components in heating and sanitary engineering. The clear panel is mounted on a sturdy, movable frame.

The trainer consists of five pipe sections, in each of which different shut-off valves and fittings are fitted. The pipe sections can be individually selected via ball valves.

One of the pipe sections is transparent with a transparent ball valve in order to visualise the flow conditions upstream and downstream of a shut-off valve. The flow is adjusted using valves in the inlet and outlet and read on a rotameter.

The pressure measuring points in the pipe system are designed as annular chambers and are located directly upstream and downstream of the valves and fittings, ensuring a precise pressure measurement. The sensors are connected in pairs to a differential pressure meter and the respective differential pressure read on the display.

HL 113

Installation technology: losses in valves and fittings

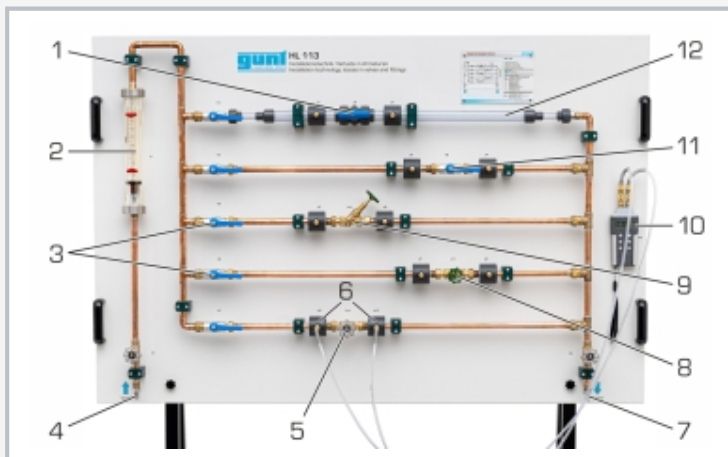

1 ball valve (transparent; plastic), 2 rotameter, 3 ball valves for selecting pipe sections, 4 water supply, 5 gate valve, 6 annular chambers as pressure measuring points, 7 drain, 8 screw-down valve, 9 angle seat valve, 10 differential pressure meter, 11 ball valve, 12 transparent pipe section

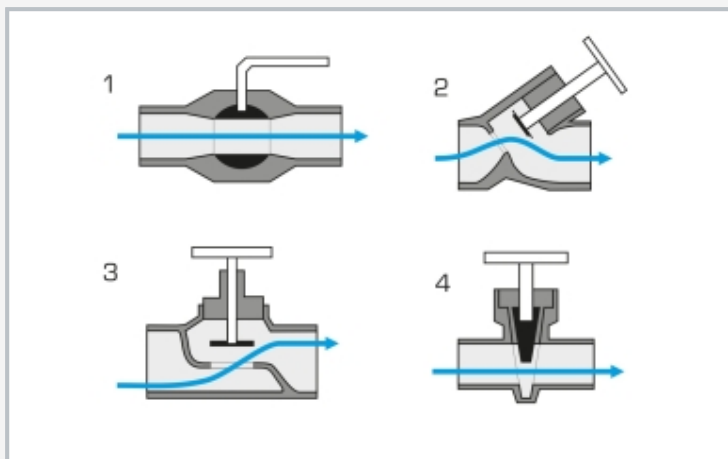

Schematic cross-sectional representation of the various valves and their function: 1 ball valve, 2 angle seat valve, 3 screw-down valve, 4 gate valve

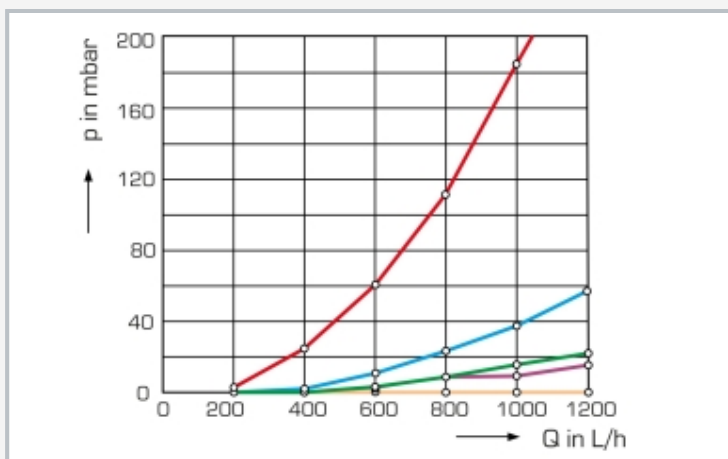

Pressure loss in the valves and fittings at different flow rates: red: screw-down valve, blue: angle seat valve, green: gate valve, purple: ball valve DN15, orange: ball valve DN32; p pressure, Q flow rate

Specification

- [1] investigation of the pressure losses at various shut-off valves and fittings
- [2] pipe elements are commercially standard components in heating and sanitary engineering
- [3] clear panel mounted on a sturdy, movable frame
- [4] pipe sections can be individually selected via ball valves
- [5] water connections with quick-release couplings
- [6] flow can be adjusted via valves
- [7] flow measurement using rotameter
- [8] differential pressure measurement via differential pressure meter with display

Technical data

- Ball valve, plastic, transparent, Ø: DN32
- Ball valve, steel, Ø: DN15
- Angle seat valve, Ø: DN15
- Screw-down valve, Ø: DN15
- Gate valve, Ø: DN15
- Differential pressure meter

- Measuring ranges
- flow rate: 200...1700L/h
 - pressure: ±200mbar

LxWxH: 1650x700x1850mm
Weight: approx. 90kg

Required for operation

water connection, drain

Scope of delivery

- 1 trainer
- 1 differential pressure meter
- 1 set of connecting hoses
- 1 set of instructional material