

HL 111

Installation technology: losses in straight pipes



Learning objectives/experiments

- hydrostatic pressure
- flow pressure
- pressure loss
- representation of pressure curves

Description

- **pressure losses in straight pipes**
- **visualisation of the hydrostatic pressure and of the flow pressure**

The pressure curves of fluids in motion and fluids at rest in pipes are fundamentally different from one another. For the same supply pressure, losses occur in flowing fluids due to the pipe friction; these losses manifest themselves as pressure losses. In fluids at rest the static pressure in horizontal pipe elements is constant.

HL 111 visualises the pressure curve of flowing and static incompressible fluids in pipes. The trainer is suitable for explaining concepts such as the hydrostatic pressure in static and moving liquids. The clear panel is mounted on a sturdy, movable frame.

The supply pressure is generated by an elevated tank. In order to ensure a constant supply pressure, the tank is fitted with a refill mechanism and an overflow. A measuring section is located at the end of the tank. The flow and thus the flow velocity can be adjusted at two points.

There are six pressure measuring points along the measuring section. The respective pressures can be read via the tube manometer with reference to the height of the liquid column.

HL 111

Installation technology: losses in straight pipes

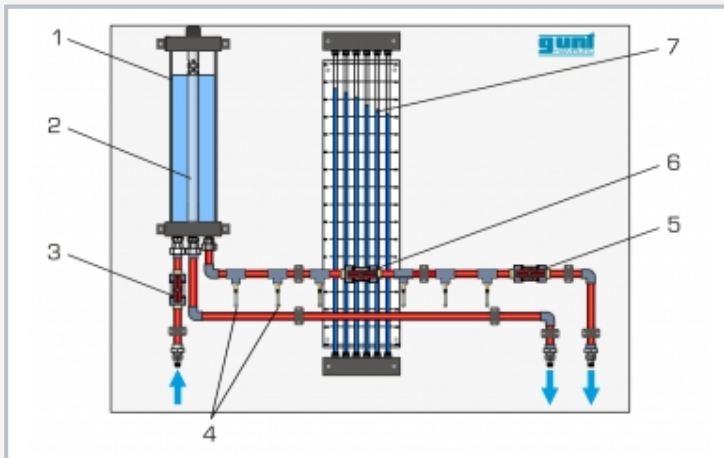

1 elevated tank, 2 overflow, 3 ball valve for inflow, 4 pressure measuring points with annular chambers, 5 ball valve for the drain, 6 adjustable resistor, 7 tube manometer panel

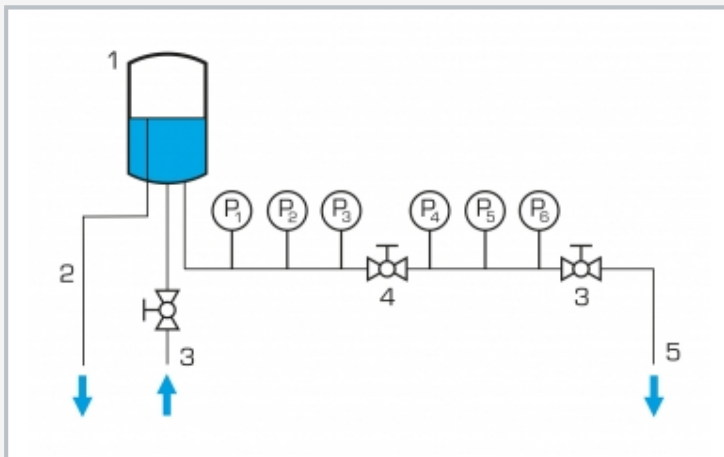

Process schematic: 1 tank, 2 overflow, 3 inflow/drain adjustment, 4 adjustable resistor, 5 water drain

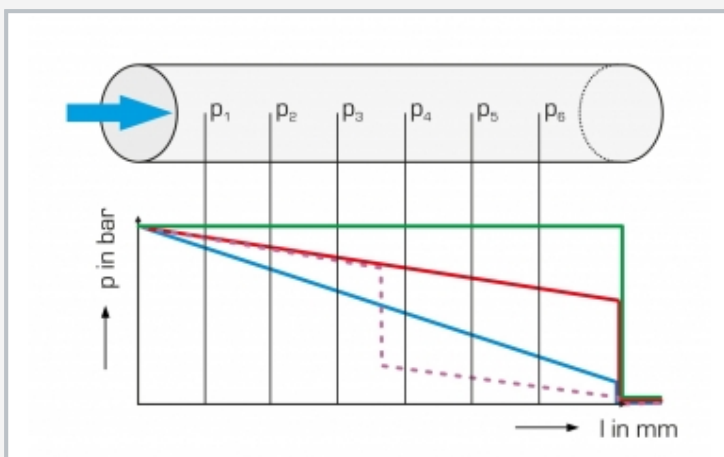

Linear pressure loss in the flow-through pipe element: p_1 to p_6 pressure measuring points; green: no flow, red: at mean flow velocity, blue: at full flow velocity, dashed purple: at mean flow velocity and resistance set via intermediary ball valve

Specification

- [1] pressure losses in the open pipe system
- [2] clear panel mounted on a sturdy, movable frame
- [3] transparent elevated tank with overflow to feed the pipe section
- [4] constant static supply pressure
- [5] flow can be adjusted via ball valves
- [6] measuring section with 6 measuring points
- [7] pressure displayed with 6 tube manometers

Technical data

Tank: approx. 8L
6 tube manometers

Measuring ranges

- pressure: -200...600mmWC

LxWxH: 1650x700x1850mm

Total weight: approx. 90kg

Required for operation

water connection, drain

Scope of delivery

- 1 trainer
- 1 set of instructional material