

# HL 102

## Installation technology: losses in different pipes



### Description

- **pressure loss in pipes**
- **different materials and diameters**

When flow passes through pipes, pressure losses occur due to the friction between the pipe wall and the water. The pressure loss is directly dependent on the surface roughness of the pipe inner wall, and thus on the material used. In addition, the pressure loss is affected by the flow velocity and the cross-sectional area being flowed through.

The HL 102 unit makes it possible to study the pressure loss of incompressible fluids in fully flowed through straight pipe elements. The trainer is suitable for assessing how different materials and pipe diameters affect the flow. The pipe elements used are commercially standard components in heating and sanitary engineering. The clear panel is mounted on a sturdy, movable frame. The four pipe sections are replaceable. Individual measuring sections can be inserted into the pipe system for investigation.

Four straight pipe elements are mounted on the panel. These can be selected individually by ball valves. The differential pressure across the pipe system is limited using an overflow valve. The flow is adjusted using valves in the inflow and return and read on a rotameter.

The pressure measuring points in the pipe system are designed as annular chambers and are located between the beginning and end of the measuring sections, ensuring a precise pressure measurement. The sensors are connected in pairs to a differential pressure meter and the respective differential pressure read on the display.

### Learning objectives/experiments

- investigation of the pressure losses of flow through pipes
  - ▶ measurement of the pressure differential on different pipe sections
  - ▶ influence of various pipe diameters
  - ▶ influence of different materials and surface roughness
  - ▶ effect of the flow velocity
  - ▶ comparison between experiment and theory

# HL 102

## Installation technology: losses in different pipes

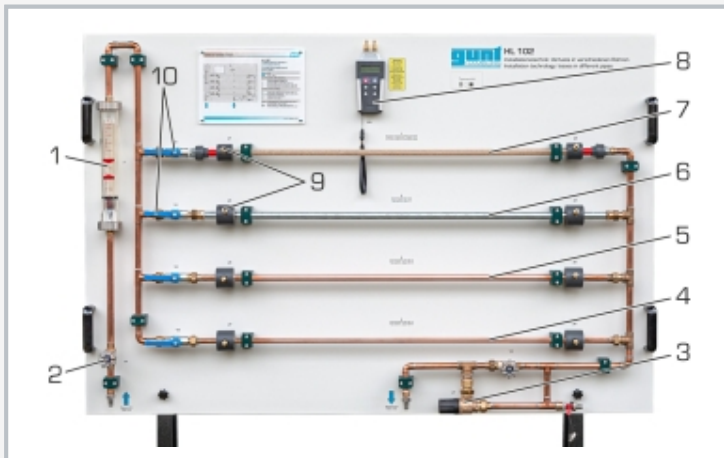

1 flow meter, 2 inflow valve, 3 overflow valve, 4 copper pipe section 15x1mm, 5 copper pipe section 18x1mm, 6 steel pipe section 1/2", 7 transparent plastic pipe section, 8 differential pressure meter, 9 pressure measuring points, 10 ball valves for selecting pipe sections

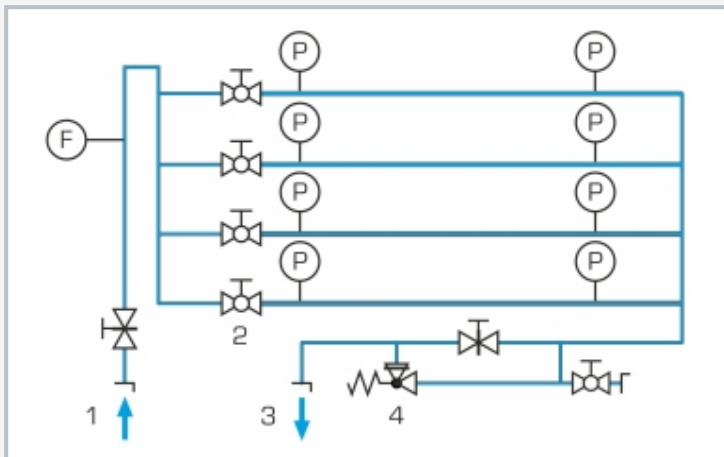

Process schematic with position of the measuring points: 1 inflow, 2 ball valve for selecting the measuring section, 3 return, 4 overflow valve; P pressure, F flow

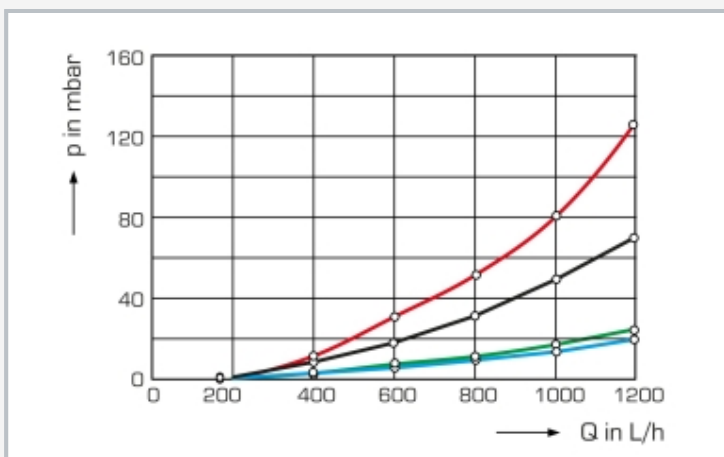

Measured differential pressures at different flow rates: red: plastic, black: copper  $\varnothing$  15x1mm, green: steel  $\varnothing$  1/2", blue: copper  $\varnothing$  18x1mm; Q flow rate, p pressure

### Specification

- [1] investigation of friction-induced pressure losses in flow through pipes
- [2] pipe elements are commercially standard components in heating and sanitary engineering
- [3] clear panel mounted on a sturdy, movable frame
- [4] four measuring sections with different pipe cross-sections and materials
- [5] own individual measuring sections with annular chambers for pressure measurement can be used
- [6] pipe sections can be selected via ball valves
- [7] overflow valve ensures pressure equalisation
- [8] water connections made using quick-release couplings in the inflow and return
- [9] flow can be adjusted via valves
- [10] flow measurement using rotameter
- [11] differential pressure measurement via differential pressure meter with display

### Technical data

- Measuring length of pipe sections: 1000mm
- Pipe section 1: plastic roughened,  $\varnothing$ : 20x1,5mm
- Pipe section 2: steel,  $\varnothing$ : 1/2"
- Pipe section 3: copper,  $\varnothing$ : 18x1mm
- Pipe section 4: copper,  $\varnothing$ : 15x1mm
- Differential pressure meter
  - max. overpressure: 1000mbar
- Measuring ranges
  - flow rate: 150...1600L/h
  - differential pressure:  $\pm$ 350mbar

LxWxH: 1650x700x1850mm  
Weight: approx. 92kg

### Required for operation

water connection 1500L/h, drain

### Scope of delivery

- 1 trainer
- 1 differential pressure meter
- 1 set of hoses
- 1 set of instructional material