

## GL 212

### Dynamic behaviour of multistage planetary gears



#### Learning objectives/experiments

- determine the transmission ratio for a locked gear
- measure transmitted forces for a locked gear
- gear acceleration under constant driving torque
- influence of the transmission ratio
- determine reduced mass moment of inertia
- conversion of potential energy into kinetic energy
- determine friction
- determine gear efficiency

#### Description

- two-stage planetary gears with three planet gears each
- four different transmissions can be configured
- bending beams to measure force
- inductive speed sensors for speed-time diagrams to determine the angular acceleration

The planetary gear is a special type of gear drive, in which the multiple planet gears revolve around a centrally arranged sun gear. The planet gears are mounted on a planet carrier and engage positively in an internally toothed ring gear. Torque and power are distributed among several planet gears. Sun gear, planet carrier and ring gear may either be driving, driven or fixed. Planetary gears are used in automotive construction and shipbuilding, as well as for stationary use in turbines and general mechanical engineering.

The GL 212 unit allows the investigation of the dynamic behaviour of a two-stage planetary gear. The trainer consists of two planet gear sets, each with three planet gears. The ring gear of the first stage is coupled to the planet carrier of the second stage. By fixing individual gears, it is possible to configure a total of four different transmission ratios. The gear is accelerated via a cable drum and a variable set of weights. The set of weights is raised via a handwheel. A ratchet prevents the weight from accidentally escaping. A clamping roller free-wheel enables free further rotation after the weight has been released. The weight is caught by a shock absorber. A transparent protective cover prevents accidental contact with the rotating parts.

To be able to determine the effective torques, the deflection on bending beams is recorded for force measurement. Inductive speed sensors on all drive gears allow the speeds to be measured. The measured values are transmitted directly to a PC via USB. The data acquisition software is included. The angular acceleration can be read from the diagrams. Effective mass moments of inertia are determined by the angular acceleration.

# GL 212

## Dynamic behaviour of multistage planetary gears



1 dial gauge, 2 bending beam, 3 set of weights, 4 set of weights for measuring transmission ratios, 5 planetary gear, 6 handwheel, 7 protective cover

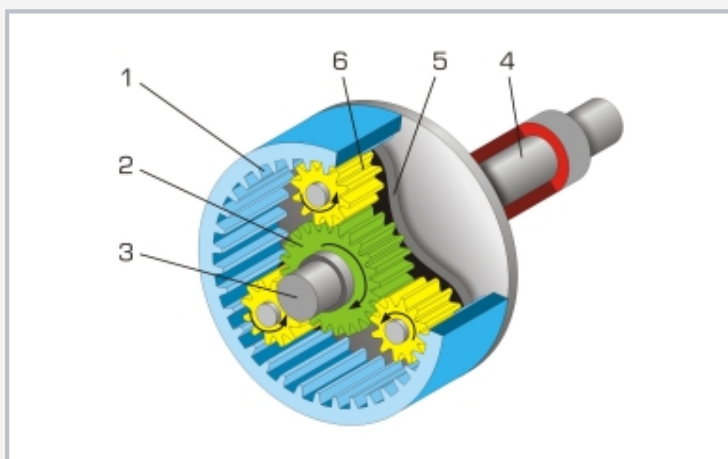

Layout of a planetary gear: 1 ring gear, 2 sun gear, 3 sun gear shaft, 4 planet carrier shaft, 5 planet carrier, 6 planet gear

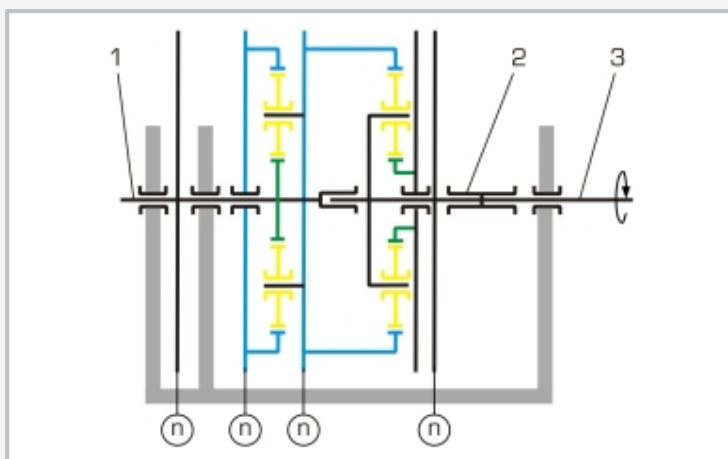

Principle of operation of a 2-stage planetary gear: 1 output shaft, 2 cable drum, 3 drive shaft, green: sun gears, yellow: planet gears, blue: ring gears, n speed

### Specification

- [1] investigation of the dynamic behaviour of a 2-stage planetary gear
- [2] three planet gears per stage
- [3] four different transmission ratios possible
- [4] gear is accelerated via cable drum and variable set of weights
- [5] weight raised by handwheel; ratchet prevents accidental release
- [6] clamping roller freewheel enables free further rotation after the weight has been released
- [7] shock absorber for weight
- [8] safety devices: transparent protective cover with safety lock and protective grill for the set of weights
- [9] force measurement on different gear stages via 3 bending bars, display via dial gauges
- [10] inductive speed sensors
- [11] GUNT software for data acquisition via USB under Windows 10

### Technical data

#### 2-stage planetary gear

- module: 2mm
- sun gears: 24-tooth, d-pitch circle: 48mm
- planet gears: 24-tooth, d-pitch circle: 48mm
- ring gears: 72-tooth, d-pitch circle: 144mm

#### Drive

- set of weights: 5...50kg
- max. potential energy: 245,3Nm

#### Load at standstill

- weight forces: 5...70N

#### Measuring ranges

- speed: 0...2000min<sup>-1</sup>

230V, 50Hz, 1 phase

230V, 60Hz, 1 phase; 120V, 60Hz, 1 phase

UL/CSA optional

LxWxH: 950x600x1700mm

Weight: approx. 150kg

### Required for operation

PC with Windows

### Scope of delivery

- 1 trainer
- 2 sets of weights
- 1 GUNT software + USB cable
- 1 set of instructional material