

CE 310.05

Plug-flow reactor



Learning objectives/experiments

- fundamentals of a saponification reaction
- continuous operation
- conversion depending on
 - ▶ retention time
 - ▶ temperature
 - ▶ concentration
- retention time distribution



Description

- plug-flow reactor for connection to supply unit CE 310
- continuous operation
- fixed bed with glass spheres
- transparent materials to observe the process
- isothermal operation
- determination of the conversion in a saponification reaction

Plug flow reactors are tubular reactors and are operated continuously. They allow analyses of chemical reactions under defined conditions.

CE 310.05 is part of a device series that enables experiments with different reactor types. In conjunction with the supply unit CE 310, it is possible to examine the function and behaviour of a plug-flow reactor in continuous operation.

The supply unit CE 310 has a heating water circuit as well as all necessary connections, pumps, tanks for reactants and a product tank. In combination with WL 110.20 Water Chiller and the supply unit CE 310 it is also possible to cool the reactors.

CE 310.05 is mounted onto the supply unit and held by two pins in position. Quick-release couplings enable easy connection of the reactor to the supply unit.

In continuous operation, two pumps on the supply unit deliver the reactants into the reactor. The fixed bed with glass spheres results in a flow over the entire cross-section of the reactor. The product is formed by reaction of the reactants. The mixture of product and unconverted reactants leaves the reactor through the upper end. The mixture is transported into a tank of the supply unit via an additional peristaltic pump.

The retention time of the reactants in the reactor is adjusted via the speed of the pumps on the supply unit.

The conversion in the plug-flow reactor is determined by measuring the conductivity. A combined conductivity/temperature sensor is included in CE 310. Conductivity and temperature are digitally displayed on the switch cabinet of the supply unit. In addition, the measured values can be captured and processed with data acquisition software (included in CE 310).

CE 310.05

Plug-flow reactor

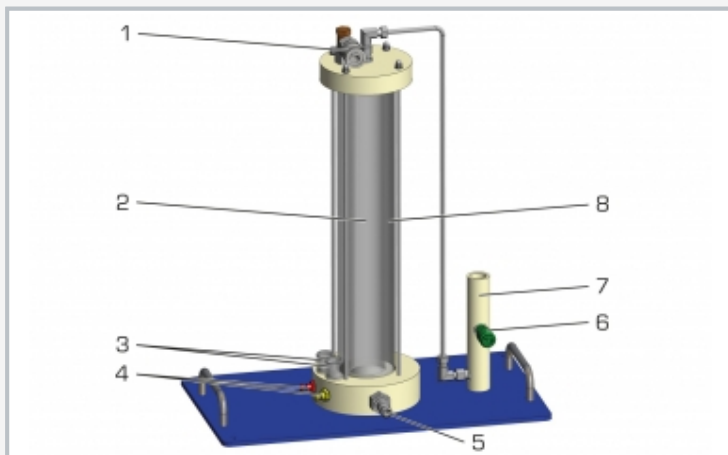

1 water drain, 2 reactor with fixed bed, 3 air vessel, 4 reactants A/B supply, 5 water supply, 6 product drain, 7 sleeve for sensor for conductivity and temperature (included in CE 310), 8 double jacket for water

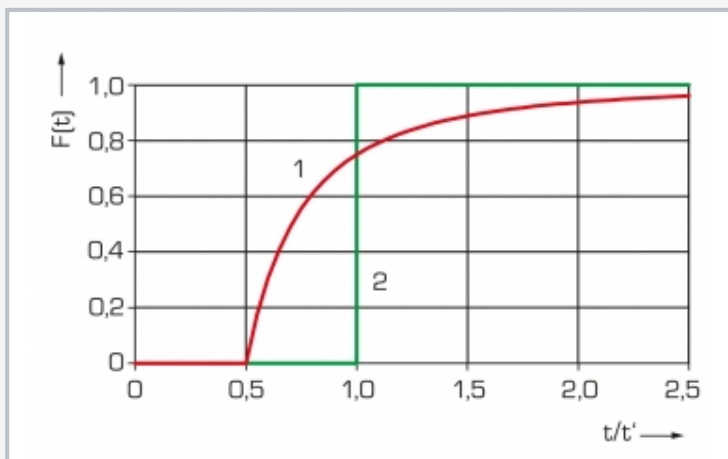

1 laminar flow, 2 plug-flow; $F(t)$ retention time cumulative curve, t time, t' retention time

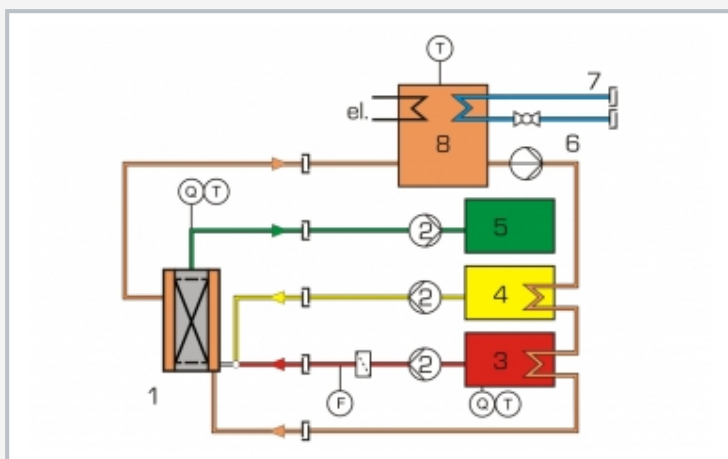

Process schematic with supply unit CE 310

1 plug-flow reactor, 2 peristaltic pump, 3 reactant A tank, 4 reactant B tank, 5 product tank, 6 water pump, 7 water connection, 8 water tank; Q conductivity, F flow rate, T temperature

Specification

- [1] plug-flow reactor for connection to supply unit CE 310
- [2] air vessel for damping of pulsation
- [3] T-piece with nozzle for mixing the reactants
- [4] straight glass tube with fixed bed from glass spheres as reactor
- [5] transparent double jacket from PMMA for cooling and heating with CE 310 and WL 110.20
- [6] sensor for measuring the conductivity and temperature via CE 310
- [7] temperature control in the reactor via CE 310

Technical data

Plug-flow reactor

- inside diameter: 40mm
- height: 400mm
- material: glass

Water bath

- inside diameter: 70mm
- capacity: approx. 0,4L
- material: PMMA

LxWxH: 440x250x530mm

Weight: approx. 15kg

Scope of delivery

- 1 plug-flow reactor

CE 310.05

Plug-flow reactor

Required accessories

083.31000 CE 310 Supply unit for chemical reactors