

FL 130

Stress and strain analysis on a thin-walled cylinder



Description

- strain on a vessel under internal pressure
- cylinder with strain gauge application as vessel
- uniaxial or biaxial stress state shown in the experiment

Pipes, pressure vessels, steam boilers etc. are considered as thin-walled vessels during design. The principal stresses are key variables in calculating and designing these vessels. The stresses and strains occurring in a vessel are not directly measured but are determined by measuring the strains on the surface using strain gauges.

The FL 130 experimental unit is used to investigate stresses and strains in a thin-walled vessel subjected to internal pressure. The oil-filled vessel is closed with a lid at one end and with a movable piston at the other end. A hand wheel with a threaded spindle is used to move the piston. Two load cases are presented: biaxial stress state of a closed vessel such as a boiler tank and uniaxial stress state of an open vessel such as a pipe.

Internal pressure is generated inside the vessel by a hydraulic pump. A manometer indicates the internal pressure. Strain gauges are attached to the surface of the vessel to record the strains. The FL 152 measuring amplifier displays the measured values. The measured values can be imported into the application software for visualisation to assist in the evaluation of the experiment.

Mohr's stress circle is used to graphically represent the conversion of the strain and to determine the principal strains. The principal stresses are calculated from the principal strains by applying the law of elasticity.

Learning objectives/experiments

- measure strains with strain gauges
- application of Mohr's stress circle to determine the principal strain
- determine the principal stresses: axial and circumferential stresses by magnitude and direction
 - ▶ in an open vessel (pipe)
 - ▶ in a closed vessel (boiler)
- comparison of open/ closed vessels
- determine Poisson's ratio
- investigation of relations between strains, pressure and stresses in a plane biaxial stress state

FL 130

Stress and strain analysis on a thin-walled cylinder

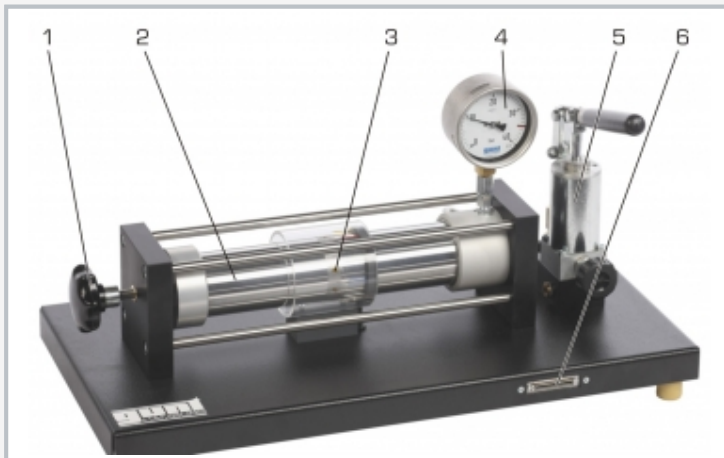

1 hand wheel for adjusting the piston, 2 vessel, 3 strain gauge measuring point, 4 manometer, 5 hydraulic cylinder with hydraulic pump, 6 port for FL 152 measuring amplifier

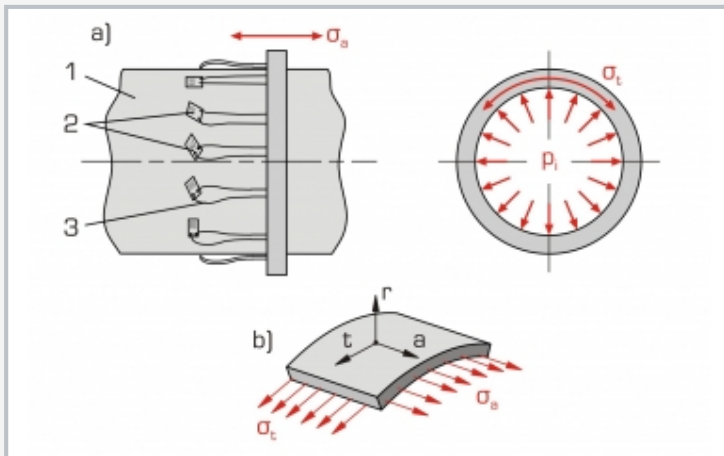

a) Strain gauge layout on the vessel: 1 vessel, 2 strain gauge measuring points, 3 wiring; σ_a stress in the direction of the vessel axis, σ_t stress in the circumferential direction, p_i internal pressure;
b) plane stress state in the wall: a axial direction, t circumferential direction, r radial direction

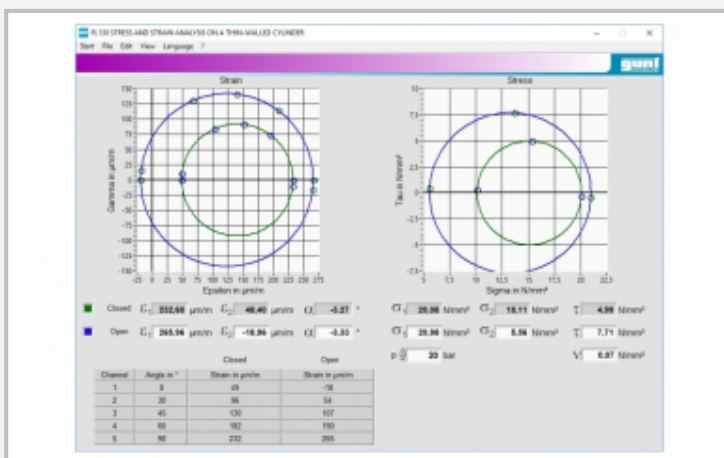

Software screenshot FL 152: Mohr's stress circle

Specification

- [1] investigation of stresses in a thin-walled vessel under internal pressure
- [2] cylinder can be used as open pipe or closed vessel
- [3] strain gauge application on the vessel surface under varying angles
- [4] hermetically sealed hydraulic system, maintenance-free, for generating the compressive load
- [5] hydraulic system with hydraulic pump and manometer
- [6] FL 152 measuring amplifier required
- [7] software for analysing measured values in FL 152

Technical data

Aluminium vessel

- length: 400mm
- diameter: $\varnothing=75\text{mm}$
- wall thickness: 2,8mm
- internal pressure: max. $3,5\text{N/mm}^2$ (35bar)

Strain gauge application

- 5 strain gauges: half-bridges, 350 Ohm
- angular position to the vessel axis: $0^\circ, 30^\circ, 45^\circ, 60^\circ, 90^\circ$
- gauge factor: $2,00 \pm 1\%$
- power supply: 10V

Manometer

- 0...40bar
- accuracy: class 1,0

LxWxH: 700x350x350mm

Weight: approx. 21kg

Scope of delivery

- 1 experimental unit
- 1 set of instructional material

FL 130

Stress and strain analysis on a thin-walled cylinder

Required accessories

021.15200 FL 152 Multi-channel measuring amplifier

Optional accessories

020.30009 WP 300.09 Laboratory trolley