

CE 287

Plate and frame filter press



Description

- separation of solids from suspensions with a plate and frame filter press
- discontinuous cake filtration
- practical experiments on a laboratory scale

Plate and frame filter presses are used in the beverage industry, for example, to clarify intermediate products.

A suspension of diatomite and water (recommended) is prepared in a tank. A pump ensures that the solid remains suspended and does not settle. The pump delivers the suspension into the individual separating chambers of the plate and frame filter press. A separating chamber is formed by one filter frame and two filter plates. The filter plates are grooved and covered over with filter cloths. The filtrate passes through the filter cloth and flows via the grooves in the plates into a collecting pipe. The filtrate exits the plate and frame filter press through the collecting pipe and is collected in the filtrate tank. The solid material is separated off at the filter cloth, where it forms a growing filter cake.

As the filter cake becomes thicker, its flow resistance also increases. When the separating chamber is full, or a maximum pressure difference has been reached, the filtration process is ended. The plates and frames of the plate and frame filter press are pulled apart. The filter cake can be removed. For the next filtration the plates and frames must be pushed back together. A spindle is used to press them together. The press forces ensure that the suspension does not leak from the contact points between the plates and the frames, but is forced through the filter cloth.

The flow rate through the plate and frame filter press is adjusted by a valve. The pressure occurring during filtration is indicated on a manometer. The filtrate tank is scaled. This means a stopwatch can be used to measure the flow rate. An included opacimeter allows the solid concentration of the filtrate to be determined. A drying chamber is recommended for evaluation of the experiments.

Learning objectives/experiments

- learning the fundamental principle and method of operation of a plate and frame filter press
- production of a suspension
- removal of the filter cake
- insertion of the filter cloth
- fundamentals of cake filtration
 - ▶ Darcy's equation
- variation in time of filtrate quantity and solid concentration in filtrate
- mass of filter cake dependent on filtrate quantity

CE 287

Plate and frame filter press



1 switch box with controls, 2 suspension tank, 3 filtrate tank outlet and overflow, 4 filtrate tank, 5 spindle, 6 plate and frame filter press

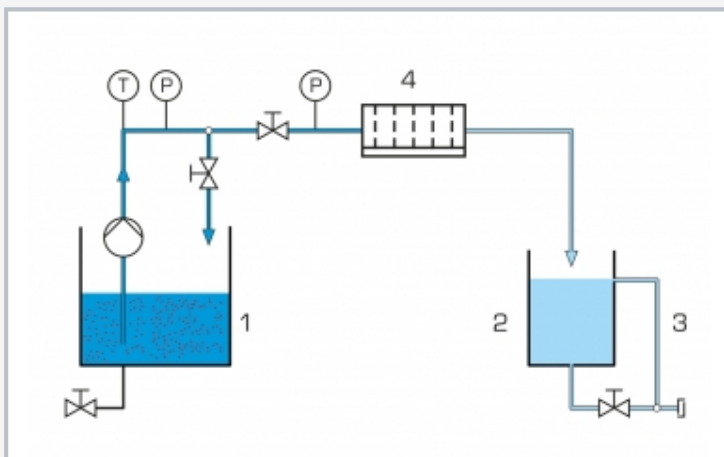

1 tank with pump, 2 filtrate tank, 3 overflow, 4 plate and frame filter press; T temperature, P pressure

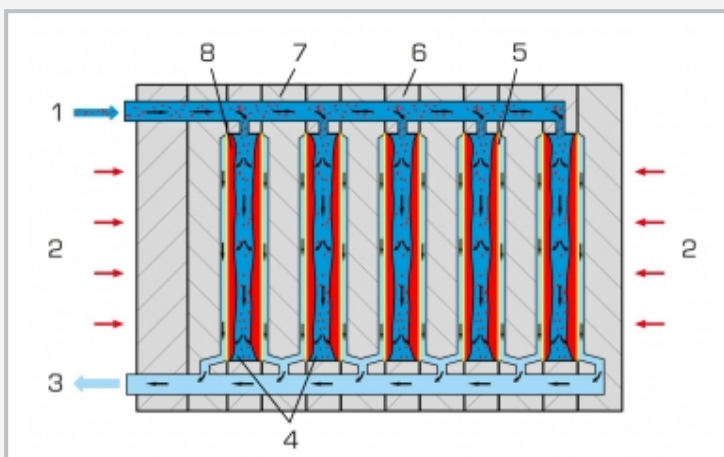

Fundamental principle of a plate and frame filter press: 1 suspension inlet, 2 press forces, 3 filtrate outlet, 4 separating chambers, 5 filter cloth, 6 filter frame, 7 filter plate, 8 filter cake

Specification

- [1] plate and frame filter press for discontinuous cake filtration
- [2] HDPE tank to produce a suspension
- [3] centrifugal pump to deliver the suspension to the plate and frame filter press
- [4] plate and frame filter press with 10 opening separating chambers for removal of the filter cake
- [5] PMMA tank with level scale for filtrate
- [6] adjustment of suspension flow rate by valve
- [7] thermometer and manometer in inlet
- [8] battery-operated opacimeter to measure the solid concentration in the filtrate

Technical data

Plate and frame filter press

- filter area: approx. 0,72m²
- working pressure: approx. 0,4...2,5bar

Centrifugal pump (submersible pump)

- max. flow rate: 4,5m³/h
- max. head: 45m

Tanks

- suspension tank: 200L
- filtrate: 20L

Measuring ranges

- pressure: 0...4bar
- temperature: 0...60°C
- opacity: 0...50,0NTU

230V, 50Hz, 1 phase

230V, 60Hz, 1 phase

120V, 60Hz, 1 phase

UL/CSA optional

LxWxH: 1900x800x1900mm

Weight: approx. 208kg

Required for operation

water connection, drain

Scope of delivery

- 1 trainer
- 1 opacimeter
- 1 packing unit of diatomite (20kg)
- 1 set of accessories
- 1 set of instructional material