

ET 915

HSI training system refrigeration and air conditioning technology, base unit



Description

- **base unit for the setup of basic experiments in refrigeration and air conditioning technology**
- **modern learning environment through hardware/software integration (HSI)**
- **four models on refrigeration and air conditioning technology**
- **dynamic recording of the refrigerant mass flow rate**

The base unit ET 915 is, dependent on the objective of the experiment, extended into complete refrigeration circuit with one of the models available as accessories (ET 915.01 refrigerator, ET 915.02 refrigeration system with refrigeration and freezing stage, ET 915.06 simple air conditioning system, ET 915.07 air conditioning).

The main components of ET 915 are compressor, condenser and receiver plus electrical and communications systems. The models are plugged onto the base unit and connected hydraulically with refrigerant hoses and electrically with cables. Self-sealing couplings reduce the refrigerant loss to a minimum. All components are arranged well visible to allow their operation to be monitored.

The modern and powerful software is an integral part of the training system in

the form of hardware/software integration (HSI). It enables the comfortable execution and analysis of the experiments. The experimental unit is connected to the PC via a USB interface.

The GUNT software consists of a software for system operation and for data acquisition and an educational software. With explanatory texts and illustrations the educational software significantly aids the understanding of the theoretical principles. Each model has its own GUNT software matching the learning objectives. With the aid of an authoring system, the teacher can create further exercises.

Temperatures and pressures in the system are recorded by sensors and displayed dynamically in the software for system operation and data acquisition. The GUNT software provides exact data on the condition of the refrigerant, which is used to calculate the refrigerant mass flow rate accurately. The calculation therefore gives a much more accurate result than measurement using conventional methods. The effect of parameter changes can be tracked in log p-h and h-x diagrams. The system is also operated via the software.

Learning objectives/experiments

- in conjunction with ET 915.01, ET 915.02, ET 915.06 and ET 915.07
 - ▶ fundamentals of the refrigeration cycle
 - ▶ fundamentals of air conditioning
 - ▶ components in a refrigeration system/air conditioning system
 - ▶ system operation
 - ▶ fault finding

ET 915

HSI training system refrigeration and air conditioning technology, base unit



1 compressor, 2 condenser with add-on fan, 3 receiver, 4 solenoid valve, 5 frame to mount the models, 6 filter/dryer, 7 manometer, 8 pressure switch, 9 refrigerant hose

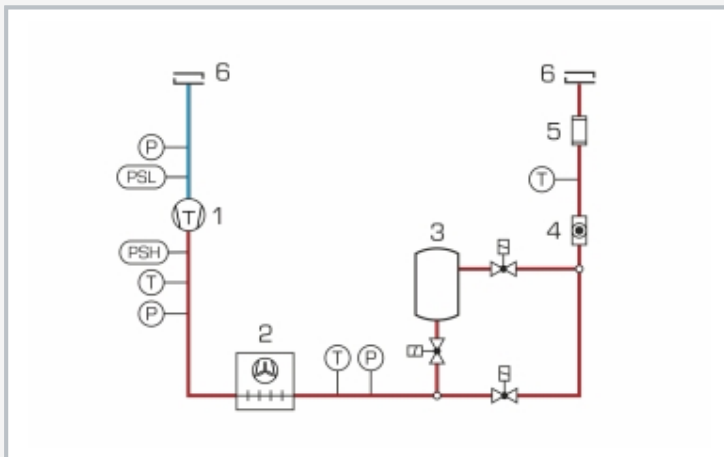

1 compressor, 2 condenser, 3 receiver, 4 sight glass, 5 filter/dryer, 6 connection for the models; PSH, PSL pressure switch; T temperature, P pressure; blue: low pressure, red: high pressure

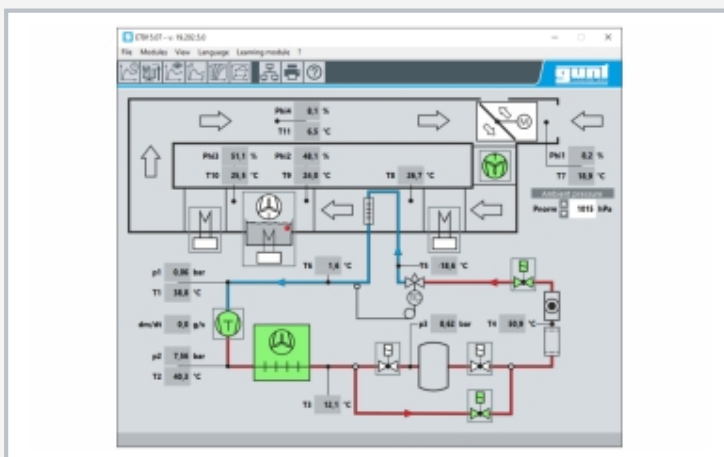

Software screenshot: process schematic of the model ET 915.07. Measured values are displayed „online“.

Specification

- [1] basic experiments on the operation of refrigeration and air conditioning systems by combining the base unit and models
- [2] GUNT training system with HSI technology
- [3] condensing unit consisting of compressor, condenser and receiver
- [4] connection between condensing unit and model via refrigerant hoses
- [5] model attached securely on ET 915 with fasteners
- [6] manometer for refrigerant with temperature scale
- [7] refrigerant mass flow rate precisely calculated via GUNT software
- [8] refrigerant R513A, GWP: 631
- [9] system control via solenoid valves and software
- [10] functions of the GUNT software: educational software, data acquisition, system operation

Technical data

Compressor

- refrigeration capacity: 463W at 7,2/54,4°C
- power consumption: 288W at 7,2/54,4°C

Receiver: 0,7L

Refrigerant

- R513A
- GWP: 631
- filling volume: 700g
- CO₂-equivalent: 0,4t

Measuring ranges

- temperature: 1x -50...50°C, 3x 0...100°C
- pressure:
 - ▶ 1x intake side: -1...9bar
 - ▶ 2x delivery side: -1...15bar
- mass flow rate: refrigerant, calculated 0...19kg/h

230V, 50Hz, 1 phase

230V, 60Hz, 1 phase

120V, 60Hz, 1 phase

UL/CSA optional

LxWxH: 830x650x320mm

Weight: approx. 60kg

Required for operation

PC with Windows

Scope of delivery

- 1 condensing unit, filled with refrigerant
- 1 authoring system for GUNT educational software
- 1 set of instructional material

ET 915

HSI training system refrigeration and air conditioning technology, base unit

Required accessories

ET 915.01	Refrigerator model
or	
ET 915.02	Model of a refrigeration system with refrigeration and freezing stage
or	
ET 915.06	Model of a simple air conditioning system
or	
ET 915.07	Air conditioning model

Optional accessories

WP 300.09	Laboratory trolley
-----------	--------------------