

ET 513

Single-stage piston compressor



Learning objectives/experiments

- setup and operating behaviour of a compressed air generation system with single-stage piston compressor
- determination of the characteristic curve
- determination of the volumetric efficiency
- determination of the mechanical efficiency

Description

- single-stage piston compressor
- part of the GUNT FEMLine
- setup of a complete compressor unit in combination with the universal drive and brake unit HM 365

The generation of compressed air for industrial and commercial purposes in areas where compressed air is used as a source of energy requires what are known as compressed air generation plants. A central part of these systems is the compressor. It is responsible for generating a pressure increase of the air by means of mechanical energy. Compressed air generation plants are used to power machines in the mining industry, for pneumatic control systems in assembly facilities or as tyre inflation units at petrol stations.

The single-stage piston compressor in ET 513 and the drive unit HM 365 together form a complete compressed air generation system.

The drive unit HM 365 powers the compressor by means of a V-belt. The speed of the compressor is set on HM 365. The air is sucked into the intake vessel, where it settles before it is compressed inside the compressor. The compressed air is then delivered to a pressure vessel and is available as a working medium. To set a steady flow operating mode, the compressed air can be discharged over a blow-off valve with a silencer. A pressure switch with a solenoid valve for limiting the pressure and a safety valve complete the system.

A measuring nozzle at the intake vessel is used to determine the suction volumetric flow rate. Sensors record the pressures and temperatures in front of and behind the compressor. The pressure is also displayed on manometers in the tanks. The measured values are read from digital displays and can be transmitted simultaneously via USB directly to a PC, where they can be analysed using the software included. The speed and torque measurement is integrated in HM 365.

ET 513

Single-stage piston compressor

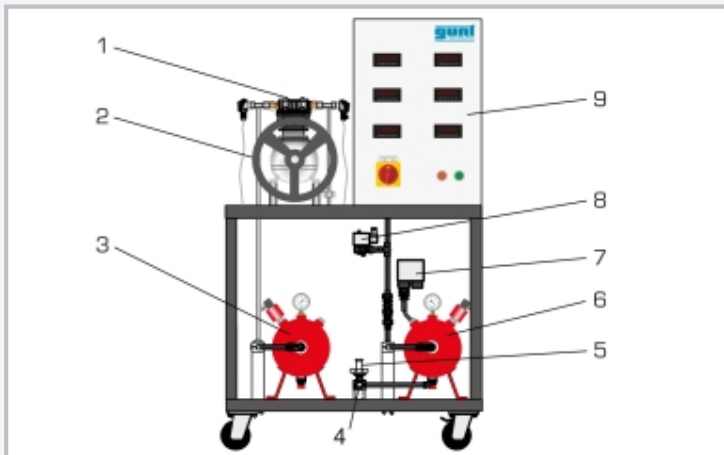

1 compressor, 2 V-belt pulley, 3 intake vessel, 4 blow-off valve with silencer, 5 safety valve, 6 pressure vessel, 7 pressure switch, 8 solenoid valve, 9 switch cabinet with digital displays

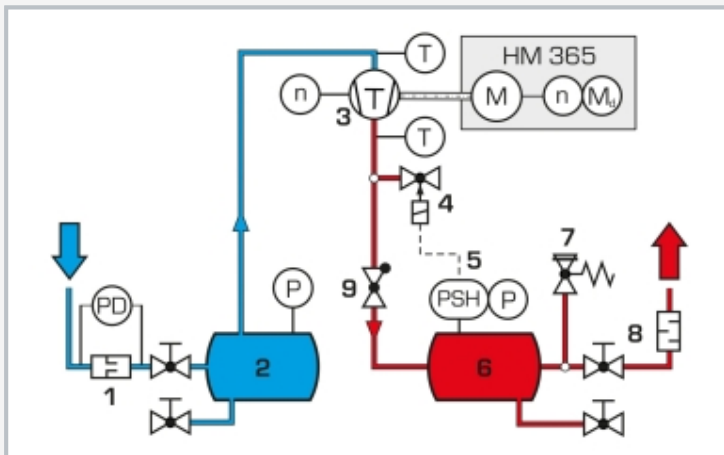

1 measuring nozzle, 2 intake vessel, 3 piston compressor, 4 solenoid valve, 5 pressure switch, 6 pressure vessel, 7 safety valve, 8 blow-off valve with silencer, 9 non-return valve; P pressure, PD differential pressure, T temperature, n speed, M_t torque



The illustration shows a complete experimental setup with ET 513 and HM 365

Specification

- [1] investigation of a driven machine for compressed air generation
- [2] single-stage piston compressor with one cylinder
- [3] drive and speed adjustment via HM 365
- [4] intake vessel with measuring nozzle for determination of the suction volumetric flow rate
- [5] intake vessel and pressure vessel, both with pressure sensor and additional manometer
- [6] safety valve and pressure switch with solenoid valve for limiting the pressure
- [7] blow-off valve with silencer for setting a steady flow operating mode
- [8] pressure and temperature sensors in front of and behind the compressor
- [9] digital display for air flow rate, temperatures, pressures, differential pressures and compressor speed
- [10] GUNT software for data acquisition via USB under Windows 10

Technical data

- Compressor, 1 cylinder, single-stage
- power consumption: 750W
 - nominal speed: 980min⁻¹
 - positive operating pressure: 8bar
 - max. pressure: 10bar
 - intake capacity: 150L/min at 8bar
 - borehole: 65mm
 - stroke: 46mm

Safety valve: 10bar

Pressure vessel

- 16bar
- volume: 20L

Intake vessel: 20L

Measuring ranges

- temperature: 1x 0...200°C / 1x 0...100°C
- pressure: 0...16bar / -1...1bar
- flow rate: 0...150L/min
- speed: 0...1000min⁻¹

- 230V, 50Hz, 1 phase
- 230V, 60Hz, 1 phase
- 120V, 60Hz, 1 phase
- UL/CSA optional
- LxWxH: 900x800x1510mm
- Weight: approx. 130kg

Required for operation

PC with Windows recommended

Scope of delivery

- 1 trainer
- 1 GUNT software + USB cable
- 1 V-belt, 1 V-belt guard
- 1 set of instructional material

ET 513

Single-stage piston compressor

Required accessories

070.36500	HM 365	Universal drive and brake unit
-----------	--------	--------------------------------

Optional accessories

for Remote Learning

010.10000	GU 100	Web Access Box
-----------	--------	----------------

with

061.51300W	ET 513W	Web Access Software
------------	---------	---------------------