

ET 422

Capacity control and faults in refrigeration systems



Description

- practice-oriented model of a commercial refrigeration system
- refrigeration and freezing chamber to investigate different methods for capacity control
- simulation of twelve faults
- two defrosting methods for freezing chamber

The efficient control of the capacity and temperature in refrigeration systems is an important topic in refrigeration technology. With ET 422 different methods of capacity control can be investigated.

The components of a refrigeration circuit with refrigeration and freezing chambers are arranged clearly in the trainer. Solenoid valves enable the separate or parallel operation of the evaporators in the two chambers. The circuit is equipped with a capacity controller, a start-up controller and a combined pressures switch for the delivery and intake sides of the compressor. One heat exchanger each in the inlet of the two evaporators enables the supercooling of the refrigerant to be investigated for the efficiency of the process. The refrigeration capacity of the two individual chambers is controlled by a thermostat. The refrigeration chamber also features an evaporation pressure controller.

There are two defrosting methods for the freezing chamber: an electric defrost heater and a hot gas defrosting where hot refrigerant is fed directly from the compressor in the opposite direction through the evaporator.

The simulation of twelve different faults, such as e.g. faulty valves or clogged pipes, is activated using a touch panel PC.

Relevant measured values are transmitted directly to the touch panel PC and analysed. The software enables e.g. the representation of the cycle in the log p-h diagram.

Learning objectives/experiments

- familiarisation with the key devices for changing the refrigeration capacity
 - ▶ thermostat
 - ▶ capacity controller
 - ▶ start-up controller
 - ▶ evaporation pressure controller
 - ▶ condensation pressure controller
- fault finding in refrigeration system components
- effect of refrigerant supercooling
- familiarisation with defrosting methods
 - ▶ electric defrost heater
 - ▶ hot gas defrosting
- representation of the thermodynamic cycle in the log p-h diagram

ET 422

Capacity control and faults in refrigeration systems



1 expansion valve, 2 freezing chamber, 3 thermostat, 4 heat exchanger, 5 solenoid valve, 6 condenser, 7 condensation pressure controller, 8 capacity controller, 9 compressor, 10 start-up controller, 11 pressure switch, 12 evaporation pressure controller, 13 flow meter, 14 refrigeration chamber, 15 touch panel PC

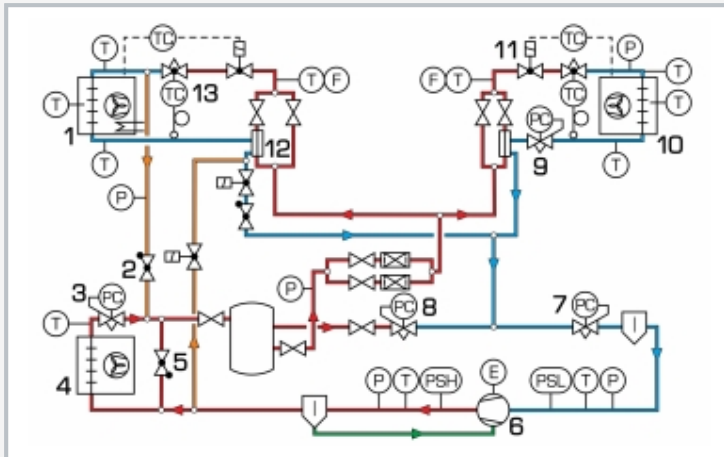

1 freezing chamber, 2 non-return valve hot gas defrosting, 3 condensation pressure controller, 4 condenser, 5 receiver pressure controller, 6 compressor, 7 start-up controller, 8 capacity controller, 9 evaporation pressure controller, 10 refrigeration chamber, 11 solenoid valve (thermostat), 12 heat exchanger, 13 expansion valve; T temperature, P pressure, F flow rate; PSH, PSL pressure switch

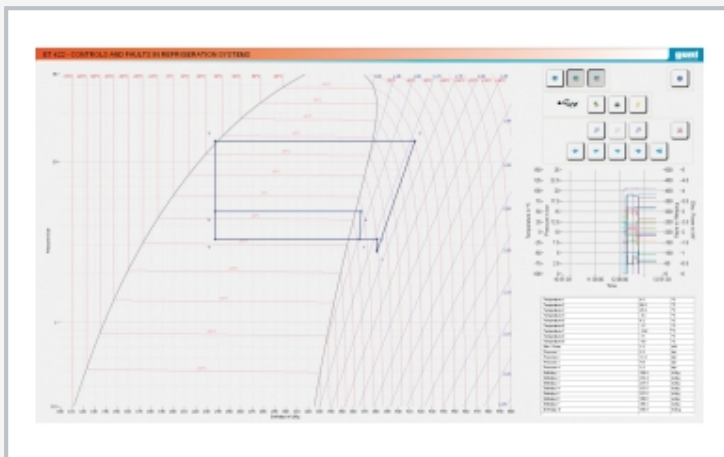

Software screenshot: log p-h diagram

Specification

- [1] investigation of a refrigeration system with refrigeration and freezing chambers
- [2] refrigeration circuit with compressor, condenser, capacity controller, start-up controller, combined pressure switch and 2 evaporators in insulated chambers
- [3] each chamber with solenoid valve, thermostat, thermostatic expansion valve, fan and heat exchanger for refrigerant supercooling
- [4] refrigeration chamber with evaporation pressure controller
- [5] freezing chamber with electric defrost heater and hot gas defrosting
- [6] separate or parallel operation of the chambers via solenoid valves
- [7] simulation of 12 faults
- [8] touch panel PC for fault activation, data acquisition, evaluation and representation in the log p-h diagram
- [9] refrigerant R449A, GWP: 1397

Technical data

Compressor

- refrigeration capacity: 1640W at -10/50°C
- power consumption: 980W at -10/50°C

Condenser with fan

- volumetric air flow rate: 570m³/h

Evaporator transfer areas

- refrigeration chamber: 1,12m²
- freezing chamber: 1,88m²

Electric defrost heater: approx. 125W

Capacity controller: 0,2...6bar

Start-up controller: 0,2...6bar

Thermostat: 2x -25...15°C

Evaporation pressure controller: 0...5,5bar

Refrigerant

- R449A
- GWP: 1397
- filling volume: 3,21kg
- CO₂-equivalent: 4,5t

Measuring ranges

- temperature: 6x -50...50°C; 5x 0...100°C
- pressure: 3x -1...15bar; 2x -1...24bar
- flow rate: 2x 2...29L/h
- power consumption: 0...5kW (compressor)

400V, 50Hz, 3 phases

230V, 60Hz, 3 phases; 400V, 60Hz, 3 phases

UL/CSA optional

LxWxH: 2420x780x1900mm

Weight: approx. 280kg

Scope of delivery

- 1 trainer
- 1 set of instructional material