

# ET 400

## Refrigeration circuit with variable load



### Learning objectives/experiments

- design and components of a refrigeration system
  - ▶ compressor
  - ▶ condenser
  - ▶ thermostatic expansion valve
  - ▶ evaporator
  - ▶ pressure switch
- representation of the thermodynamic cycle in the log p-h diagram
- determination of important characteristic variables
  - ▶ coefficient of performance
  - ▶ refrigeration capacity
  - ▶ compressor work
- operating behaviour under load

### Description

- refrigeration circuit with water circuit as load
- defined cooling load via controlled water temperature
- display of all relevant values
- dynamic recording of the refrigerant mass flow rate

ET 400 examines a refrigeration circuit under an adjustable load. The refrigeration circuit consists of a compressor, a condenser with ventilator, a thermostatic expansion valve and a coaxial coil heat exchanger as evaporator. A water circuit serves as load, consisting of a tank with a heater and a pump. The temperature in the tank is adjusted at a controller.

The purpose of this refrigeration circuit is the production of cold water. The water flows through the jacket of the coaxial coil heat exchanger, transfers heat to the refrigerant and thereby cools down.

All relevant measured values are recorded by sensors. The simultaneous transmission of the measured values to a data recording software enables easy analysis and the representation of the process in the log p-h diagram. The GUNT software provides exact data on the condition of the refrigerant, which is used to calculate the refrigerant mass flow rate accurately. The calculation therefore gives a much more accurate result than measurement using conventional methods. The software also displays the key characteristic variables of the process, such as the compressor pressure ratio and the coefficient of performance.

The clearly arranged components aid understanding.

# ET 400

## Refrigeration circuit with variable load



1 condenser with ventilator, 2 receiver, 3 high pressure switch, 4 displays and controls, 5 heater controller, 6 compressor, 7 liquid separator, 8 pump, 9 warm water tank with heater, 10 filter/drier, 11 sight glass, 12 expansion valve, 13 evaporator

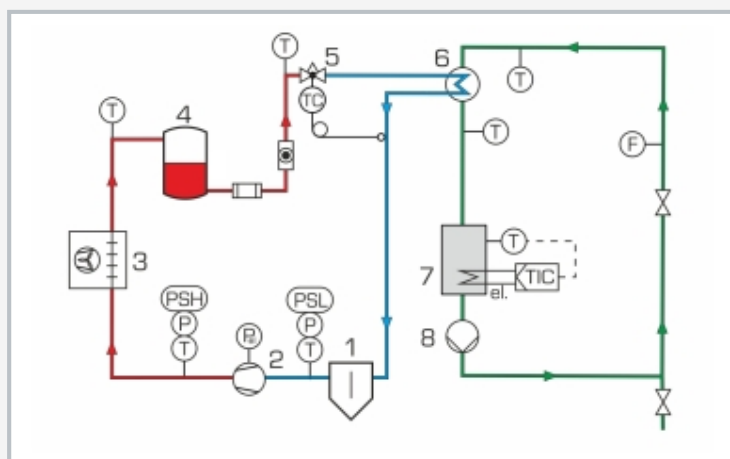

1 liquid separator, 2 compressor, 3 condenser, 4 receiver, 5 expansion valve, 6 evaporator, 7 warm water tank with heater, 8 pump; T temperature, P pressure, F flow rate, TIC temperature controller, PSH, PSL pressure switch; blue-red: refrigeration circuit, green: water circuit

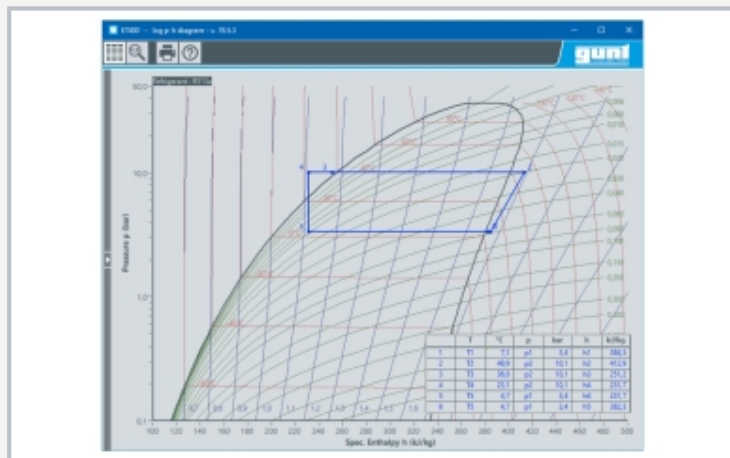

Software screenshot: log p-h diagram

### Specification

- [1] investigation of a refrigeration circuit with water circuit as load
- [2] refrigeration circuit with compressor, condenser with ventilator, thermostatic expansion valve and coaxial coil heat exchanger as evaporator
- [3] EC ventilator enables very high load variability
- [4] water circuit with pump, tank with heater as cooling load at the evaporator
- [5] heater with controller to adjust the tank temperature
- [6] recording of all relevant measured values
- [7] refrigerant mass flow rate precisely calculated via GUNT software
- [8] GUNT software for data acquisition via USB under Windows 10
- [9] refrigerant R513A, GWP: 631

### Technical data

- Compressor
- refrigeration capacity: approx. 479W at 7,2/54,4°C
  - power consumption: 168W at 7,2/54,4°C
- Evaporator
- refrigerant volume: 0,4L
  - water volume: 0,8L
- Condenser
- transfer area: approx. 1,25m<sup>2</sup>
  - air flow 0...1400m<sup>3</sup>/h
- Pump
- max. flow rate: 1,9m<sup>3</sup>/h
  - max. head: 1,4m
- Tank
- volume: approx. 4,5L
  - heater: approx. 450W
- Refrigerant: R513A, GWP: 631
- filling volume: 800g
  - CO<sub>2</sub>-equivalent: 0,5t

### Measuring ranges

- pressure: 2x -1...15bar
- power: 0...750W
- temperature: 6x 0...100°C
- flow rate:
  - ▶ water 0,05...1,8L/min
  - ▶ refrigerant calculated 0...17kg/h

230V, 50Hz, 1 phase; 230V, 60Hz, 1 phase  
 120V, 60Hz, 1 phase; UL/CSA optional  
 LxWxH: 1620x790x1910mm  
 Weight: approx. 192kg

### Required for operation

PC with Windows recommended

### Scope of delivery

trainer, GUNT software + USB cable, set of instructional material

# ET 400

## Refrigeration circuit with variable load

Optional accessories

for Remote Learning

GU 100      Web Access Box

with

ET 400W      Web Access Software