

ET 352

Vapour jet compressor in refrigeration



Learning objectives/experiments

- understanding compression refrigeration systems based on the vapour jet method
- clockwise and anticlockwise Rankine cycle
- energy balances
- calculation of the coefficient of performance of the refrigeration circuit
- thermodynamic cycle in the log p-h diagram
- operating behaviour under load
- solar thermal vapour jet refrigeration

Description

- refrigeration system with vapour jet compressor
- cold production using heat
- transparent condenser and evaporator
- together with ET 352.01 and HL 313: using solar heat as drive energy for the vapour jet compressor

Unlike standard compression refrigeration systems, vapour jet refrigeration machines do not have a mechanical but a vapour jet compressor. This makes it possible to use different heat sources for cold production. Such sources could e.g. be solar energy or process waste heat.

The system includes two refrigerant circuits: one circuit is used for cold production (refrigeration cycle), the other circuit is used for the generation of motive vapour (vapour cycle).

The vapour jet compressor compresses the refrigerant vapour and transports it to the condenser. A transparent tank with a water-cooled pipe coil serves as condenser.

In the refrigeration cycle some of the condensed refrigerant flows into the transparent evaporator connected to the intake side of the vapour jet compressor. The evaporator is a so-called flooded evaporator where a float valve keeps the filling level constant. The refrigerant absorbs the ambient heat or the heat from the heater and evaporates. The refrigerant vapour is aspirated by the vapour jet compressor and compressed again.

In the vapour cycle a pump transports the other part of the condensate into a vapour generator. An electrically heated tank with water jacket evaporates the refrigerant. The generated refrigerant vapour drives the vapour jet compressor. Alternatively to the electric heater, solar heat can be used as drive energy by using ET 352.01 and the solar thermal collector HL 313.

Relevant measured values are recorded by sensors, displayed and can be processed onto a PC. The heater power at the evaporator is adjustable. The cooling water flow rate at the condenser is adjusted using a valve.

ET 352

Vapour jet compressor in refrigeration



1 manometer, 2 pressure switch, 3 displays and controls, 4 vapour generator, 5 evaporator, 6 pump, 7 cooling water connections, 8 flow meter, 9 condenser, 10 vapour jet compressor

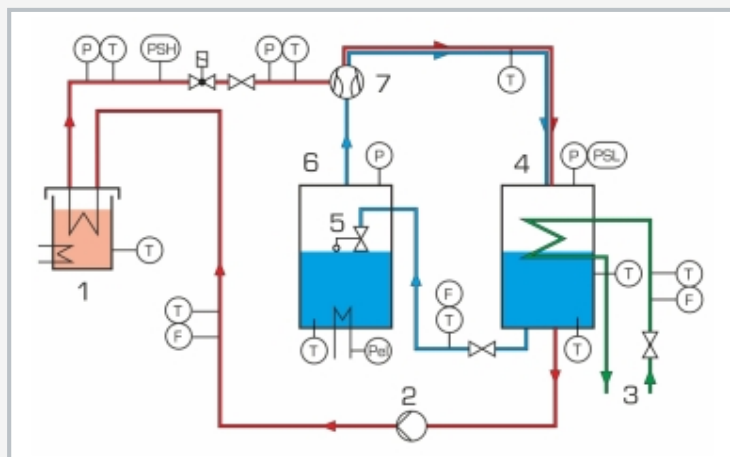

1 vapour generator, 2 pump, 3 cooling water connections, 4 condenser, 5 float valve, 6 evaporator, 7 vapour jet compressor; T temperature, P pressure, PSL, PSH pressure switch, F flow rate, P_{el} power; red: vapour cycle, blue: refrigeration cycle, green: cooling water

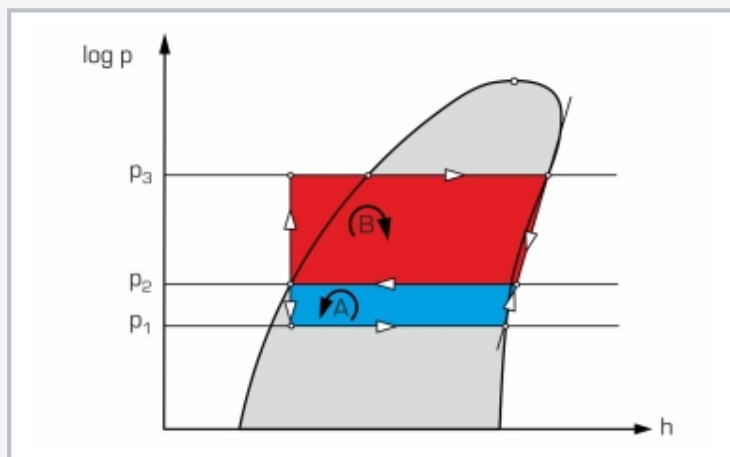

log p-h diagram: A refrigeration cycle, B vapour cycle, p_1 pressure in the evaporator, p_2 pressure in the condenser, p_3 pressure in the vapour generator

Specification

- [1] investigation of a vapour jet compressor
- [2] refrigeration circuit with condenser, evaporator and vapour jet compressor for refrigerant
- [3] vapour circuit with pump and vapour generator for operating the vapour jet compressor
- [4] transparent tank with water-cooled pipe coil as condenser
- [5] water supply via the lab network or via WL 110.20 Water chiller to ensure a maximum water temperature of 14°C
- [6] transparent tank with adjustable heater as evaporator
- [7] flooded evaporator with float valve as expansion element
- [8] vapour generator with heated water jacket (electrically or solar thermally using ET 352.01, HL 313)
- [9] refrigerant R1233zd, GWP: 1
- [10] GUNT software for data acquisition via USB under Windows 10

Technical data

Vapour jet compressor

- d_{min} convergent-divergent nozzle: approx. 1,7mm
- d_{min} mixing jet: approx. 7mm

Condenser

- tank: approx. 3,5L
- pipe coil area: approx. 0,17m²

Evaporator

- tank: approx. 3,5L
- heater power: 4x 125W

Vapour generator

- refrigerant tank: approx. 0,75L
- water jacket: approx. 9L
- heater power: 2kW

Pump

- max. flow rate: approx. 1,7L/min
- max. head: approx. 70mWS

Refrigerant: R1233zd, GWP: 1, filling volume: 5kg, CO₂-equivalent: 0t

Measuring ranges

- temperature: 12x -20...100°C
- pressure: 2x 0...10bar; 2x -1...9bar
- flow rate: 2x 0...1,5L/min, 1x 30...320L/h
- power: 1x 0...750W, 1x 0...3kW

230V, 50Hz, 1 phase

230V, 60Hz, 1 phase, 230V, 60Hz, 3 phases

UL/GSA optional

LxWxH: 1460x790x1890mm

Weight: approx. 225kg

Required for operation

water connection (min. 320L/h, water temperature max. 14°C), drain or WL 110.20
PC with Windows recommended

Scope of delivery

- 1 trainer + 1 set of accessories
- 1 GUNT software + USB cable
- 1 set of instructional material

ET 352

Vapour jet compressor in refrigeration

Optional accessories

for Remote Learning

010.10000 GU 100

Web Access Box

with

061.35200W ET 352W

Web Access Software

Other accessories

061.35201 ET 352.01

Solar heat for refrigeration

065.31300 HL 313

Domestic water heating with flat collector

065.31301 HL 313.01

Artificial light source

060.11020

WL 110.20

Water chiller