

# ET 192

## Replacement of refrigeration components



### Description

- practical service tasks in refrigeration systems
- replace typical components of a refrigeration system: compressor, pressure switch, filter/drier, solenoid valve and expansion valve
- refrigerant displacement, replacement, evacuation, filling and siphoning off

The replacement of a faulty compressor or other components of the refrigeration system are amongst the repeated activities of a mechatronics engineer for refrigeration. ET 192 allows for training in these processes. The consequences of incorrect procedures can be demonstrated.

The components are integrated into an operational refrigeration system. This allows for the practical testing of the functionality of individual components after replacement.

The following activities must be carried out e.g. after replacing a compressor:

- refrigerant displacement (pump-down) into the condenser/receiver (should this not be possible, siphoning off the refrigerant)
- disconnection of the compressor at the service valves
- disconnection of electrical connections
- compressor replacement, correcting oil level, if necessary
- reconnecting electrical connections
- reconnecting the compressor with the service valves
- evacuating the compressor and making the connection to the system
- compressor test run, checking for leaks and replenish refrigerant, if necessary
- checking the system pressures

To carry out the service tasks, the tool set ET 150.02 and the filling and evacuation equipment ET 150.01 are required.

### Learning objectives/experiments

- familiarisation with and carry out basic activities for the servicing of refrigeration systems
- replacement of
  - ▶ compressor
  - ▶ pressure switch
  - ▶ filter/drier
  - ▶ solenoid valve
  - ▶ expansion valve
- refrigerant displacement (pump-down)
- mechanical and electrical assembly and disassembly of components
- replenish refrigerant and compressor oil
- leak test
- compressor test run
- adjustment of expansion valve and pressure switch

# ET 192

## Replacement of refrigeration components

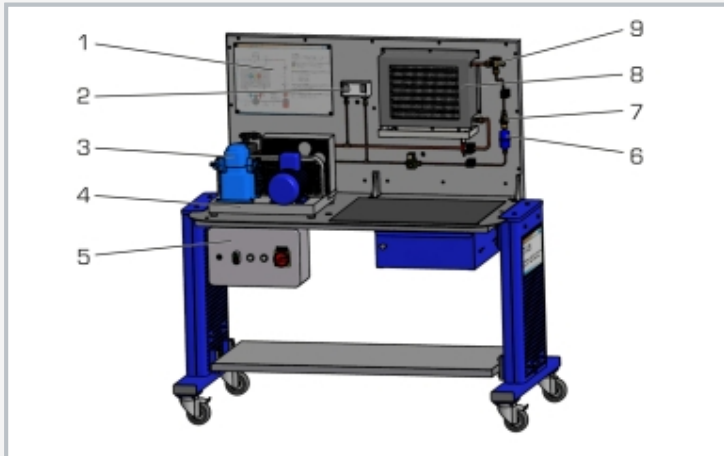

1 process schematic, 2 pressure switch, 3 condenser, 4 compressor, 5 controls, 6 filter/drier, 7 sight glass, 8 evaporator, 9 expansion valve

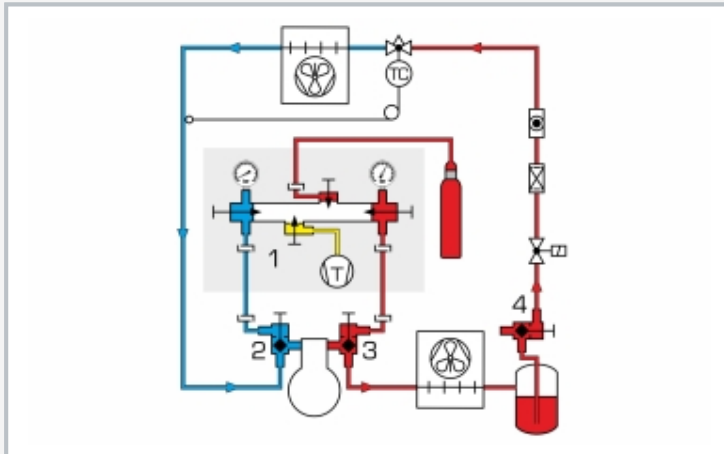

Example: valve position for normal operation, assembly aid is connected and indicates operating pressures

1 assembly aid, 2 intake side service valve, 3 delivery side service valve, 4 receiver shut-off valve; blue: low pressure, red: high pressure

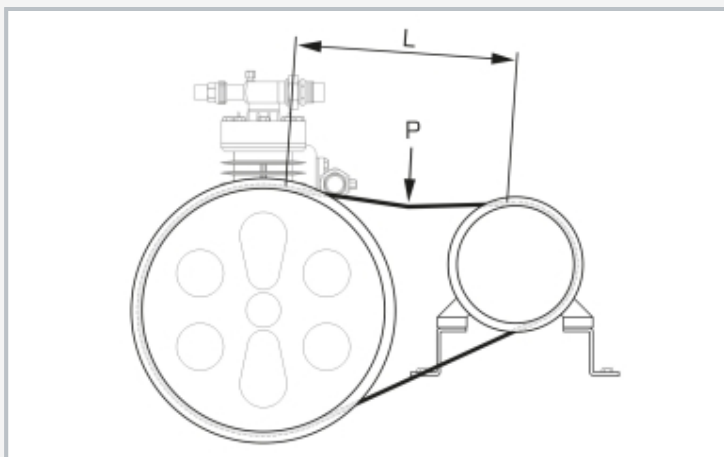

Checking and adjustment of the belt tension

### Specification

- [1] trainer from the GUNT practical series for the training of mechatronics engineers for refrigeration
- [2] service exercises in refrigeration systems
- [3] complete refrigeration circuit with open compressor, air-cooled condenser, receiver and air cooling evaporator
- [4] replaceable components: compressor, filter/drier, pressure switch and solenoid valve
- [5] required accessories evacuation equipment ET 150.01 and tool set ET 150.02
- [6] overall arrangement on robust workbench
- [7] refrigerant R513A, GWP: 631

### Technical data

Open refrigerant compressor

- refrigeration capacity: 450W at  $-5^{\circ}\text{C}/40^{\circ}\text{C}$  and  $1450\text{min}^{-1}$
- maximum system pressure: 18bar

Pressure switch

- LP:  $-0,2...7\text{bar}$
- HP:  $10...32\text{bar}$

Refrigerant

- R513A
- GWP: 631
- filling volume: 1kg
- $\text{CO}_2$ -equivalent: 0,6t

230V, 50Hz, 1 phase

230V, 60Hz, 1 phase

120V, 60Hz, 1 phase

UL/CSA optional

LxWxH: 1400x750x1650mm

Weight: approx. 150kg

### Scope of delivery

- 1 trainer
- 1 set of instructional material

# ET 192

## Replacement of refrigeration components

Required accessories

ET 150.01      Refrigerant filling and evacuation equipment  
ET 150.02      Tool set