

MT 136

Assembly exercise: gear pump

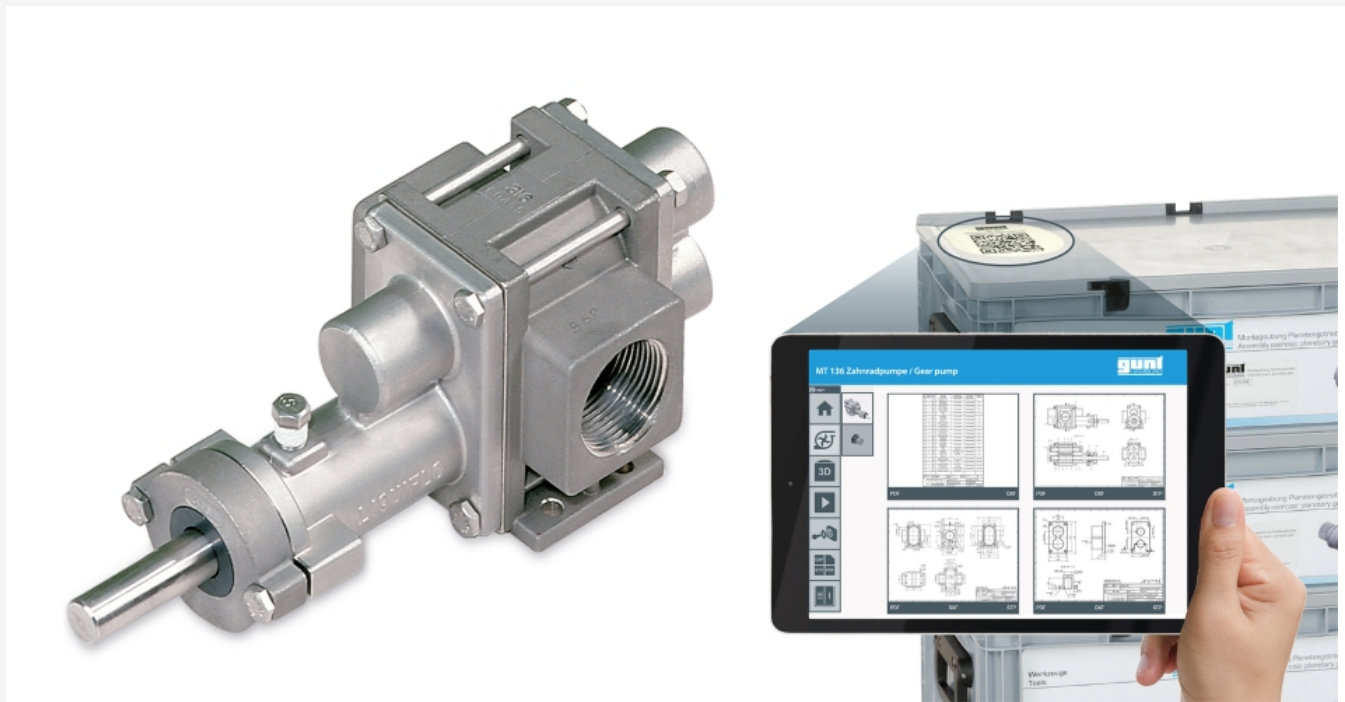

The illustration shows the device and the GUNT Media Center, tablet not included

Description

- **broad range of learning opportunities with interdisciplinary problems**
- **part of the GUNT Practice Line for assembly, maintenance and repair**
- **multimedia instructional materials on USB flash drive and online in GUNT Media Center: 3D PDF, DXF files, STEP files, videos**

Gear pumps belong to the group of circulating piston pumps, which operate according to the positive displacement principle. They have a simple design and are easy to use.

The MT 136 assembly kit is part of the GUNT Practice Line for assembly, maintenance and repair, which has been designed for technical colleges and company training centres. The close link between theory and practice-based learning content is evident. The assembly and disassembly processes can easily be completed within standard lesson times. Only basic tools, all supplied with the kit, are required for assembly. The fit seats of the gear pump are designed so that the entire assembly can be carried out by hand.

The contemporary multimedia instructional materials provide extensive technical information as base for lesson design. The core element of the teaching materials is a complete set of drawings as files with lists of parts, single-part drawings, exploded views, assembly drawings and 3D drawings. All drawings are to standard and are dimensioned in accordance with production requirements. The set of drawings consists of DXF files, STEP files and PDF files. Assembly videos are also useful features. The files are also available free of charge online in the GUNT Media Center. Dimensions, tolerances and surface details in the drawings are given as imperial measurements (inch).

The disassembled gear pump with a set of small parts and 4 assembly devices is delivered in the sturdy storage system with foam inlay. The MT 120.02 Transport roller or the MT 120.01 Trolley are suitable for convenient transport of the assembly exercise.

Learning objectives/experiments

- function and design of a gear pump
- planning and presentation of the assembly process
- assembly and disassembly, including for maintenance and repair purposes
- read and understand technical drawings in imperial measurements (PDF, DXF and STEP files)
- familiarisation with various machine elements: gears, mechanical seal
- familiarisation with assembly aids and devices
- create programmes for 3D printing and CNC machining

MT 136

Assembly exercise: gear pump

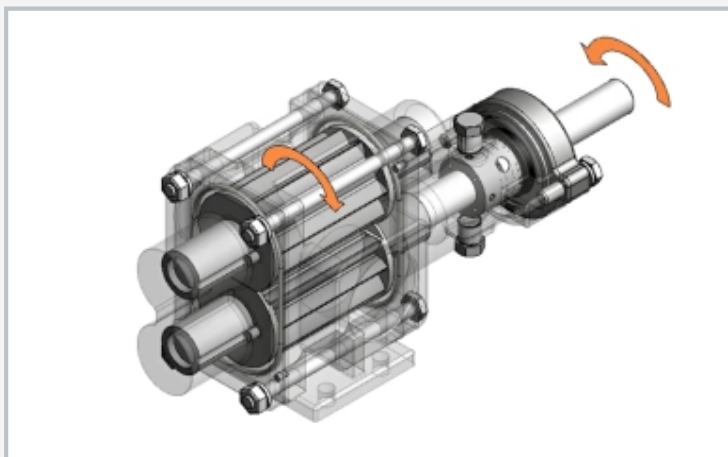

Transparent sectional drawing of the assembled gear pump



Screenshot of the GUNT Media Center



Gear pump assembly: fitting the drive shaft

Specification

- [1] gear pump assembly kit
- [2] part of the GUNT Practice Line for assembly, maintenance and repair
- [3] disassembled gear pump with set of small parts and 4 assembly devices, delivered in sturdy storage system with foam inlay
- [4] gear pump consisting of housing, drive shaft and countershaft, drive gear, driven gear, bearings, mechanical seal
- [5] multimedia teaching material: 3D PDF, CAD/STEP files, videos
- [6] dimensions, tolerances and surface details in the drawings given as imperial measurements [inch]
- [7] online access to the GUNT Media Center

Technical data

Gear pump

- power consumption: max. 2kW
- max flow rate: 80L/min
- max. delivery pressure: 7bar rel.
- motor speed: 300...1750min⁻¹
- inlet: 1 1/4" NPT
- outlet: 1 1/4" NPT
- pump materials
 - ▶ housing: stainless steel 316 (1.4401)
 - ▶ gears: stainless steel 316 (1.4401)/PTFE
 - ▶ wear plates: PTFE
 - ▶ plain bearing bushes: PTFE
 - ▶ mechanical seal: ceramic/PTFE
- speed-dependent viscosities
 - ▶ max. viscosity at n=300min⁻¹: 10000mPas
 - ▶ max. viscosity at n=1750min⁻¹: 3000mPas

LxWxH: 600x400x590mm (storage system)

Weight: approx. 20kg

Scope of delivery

- 1 kit
- 1 set of tools
- 1 set of assembly jigs
- 1 set of spare parts
- 3x storage system with foam inlay
- 1 set of instructional material: technical description of system, complete set of drawings with lists of parts (PDF, DXF, STEP), description of assembly and disassembly sequences, assembly videos, on-line access to the GUNT Media Center

MT 136

Assembly exercise: gear pump

Optional accessories

051.12001	MT 120.01	Trolley
051.12002	MT 120.02	Transport roller
070.70022	HM 700.22	Cutaway model: gear pump