

HM 222

Air flow in pipes and pipe elements



Description

- resistances and losses in laminar and turbulent pipe flow
- precise pressure measurement via annular chambers

When flow passes through pipes, pressure losses occur due to the friction between the pipe wall and the fluid. The pressure loss is directly dependent on the surface roughness of the pipe inner wall, and thus on the material used. In addition, the pressure loss is affected by the flow velocity and the cross-sectional area being flowed through.

Knowledge of pressure losses in various pipe elements is a key factor in designing pipe systems. The HM 222 trainer allows the determination by experiment of these important coefficients and the investigation of the pressure curve in typical pipe sections. Experiments can be performed with laminar and turbulent air flow.

The trainer comprises three straight pipe sections made of different materials and with different diameters. Also included are: a pipe section with a pipe angle, a pipe section with six pipe angles, an orifice plate flow meter for volumetric flow rate measurement, and a balance to measure the jet force at the end of the pipe system.

The pressure measuring points in the pipe system are designed as annular chambers and are located directly upstream and downstream of the pipe elements, ensuring a precise pressure measurement. The pressure measuring points are connected in pairs to a differential pressure meter where the respective differential pressure can be read. The volumetric flow rate is displayed on two rotameters with different measuring ranges.

Learning objectives/experiments

- pressure losses for laminar and turbulent pipe flow
- determination of the friction factor for different pipe materials and diameters (Darcy-Weisbach equation)
- pressure loss in one or several pipe angles
- study of the jet force
- function of an orifice plate flow meter
- determination of the pressure curve along the measuring section
- comparison between experiment and calculation

HM 222

Air flow in pipes and pipe elements

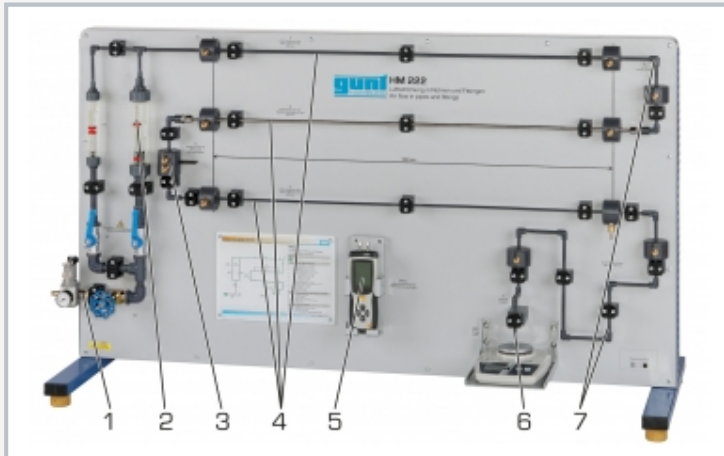

1 compressed air supply, 2 rotameter, 3 orifice plate flow meter, 4 straight pipe section, 5 differential pressure meter, 6 measurement of the jet force, 7 pipe section with pipe angle

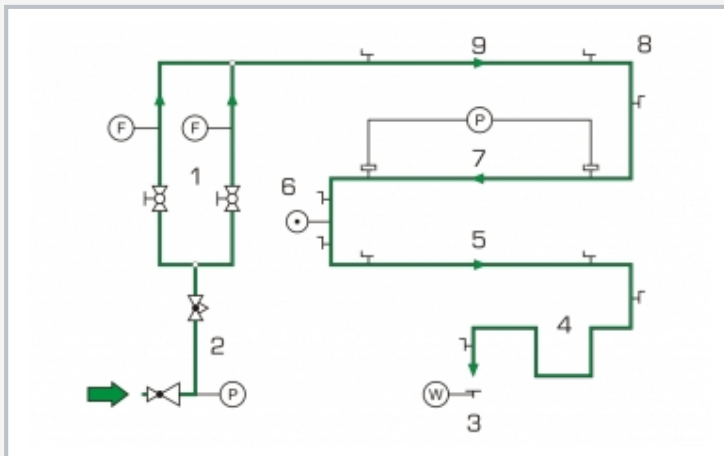

1 rotameter and adjustment of volumetric flow rate, 2 compressed air supply, 3 measurement of the jet force, 4 pipe section with pipe angles, 5 straight pipe section (6x1 mm, PVC), 6 orifice plate flow meter, 7 straight pipe section (8x1 mm, stainless steel), 8 pipe section with pipe angle, 9 straight pipe section (8x1 mm, PVC); F volumetric flow rate, P pressure, W weight

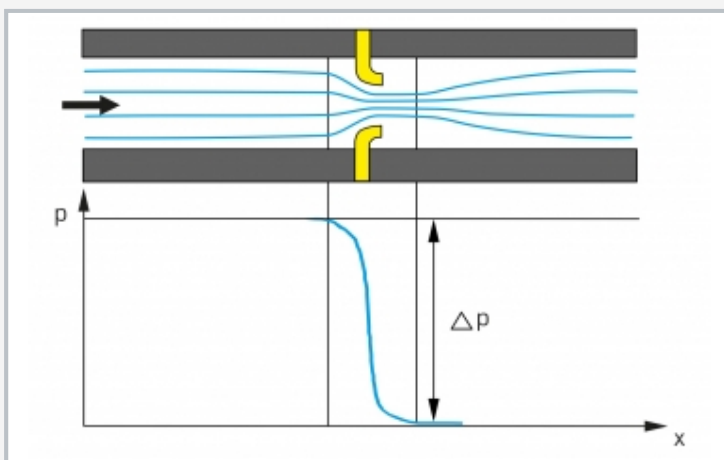

Pressure curve in an orifice plate flow meter: p pressure, x section

Specification

- [1] study of pressure losses in pipes with laminar and turbulent air flow
- [2] 3 straight pipe sections made of PVC and stainless steel with different diameters
- [3] pipe section with 1 pipe angle
- [4] pipe section with 6 pipe angles
- [5] orifice plate flow meter to determine the volumetric flow rate via pressure loss
- [6] 9 pressure measuring points with interference-free pressure measurement via annular chambers
- [7] measurement of the jet force using a balance
- [8] differential pressure measurement with differential pressure meter
- [9] volumetric flow rate measurement with rotameter

Technical data

- 3 straight pipe sections, measuring length: 1 m
- Ø 8x1 mm, PVC
 - Ø 8x1 mm, stainless steel
 - Ø 6x1 mm, PVC

- Pipe section, PVC, Ø 8x1 mm
- with 1 pipe angle, measuring length: 0,12 m
 - with 6 pipe angles measuring length: 0,8 m

- Orifice plate flow meter
- Ø 4 mm

- Balance
- measuring range: 0...2 kg, resolution: 0,001 g

- Measuring ranges
- volumetric flow rate:
 - ▶ 0,9...9 L/min
 - ▶ 8...90 L/min
 - differential pressure: 0...200 mbar
 - ▶ resolution: 0,01 mbar

LxWxH: 1570x570x900 mm
Weight: approx. 32 kg

Required for operation

compressed air [5,5 m³/h, min. 4 bar]

Scope of delivery

- 1 experimental unit
- 1 set of accessories
- 1 set of instructional material

HM 222

Air flow in pipes and pipe elements

Optional accessories

020.30009

WP 300.09

Laboratory trolley