

## CE 322

### Rheology and mixing quality in a stirred tank



#### Learning objectives/experiments

- determination of mixing characteristics
  - ▶ mixing time and degree of mixing
  - ▶ mixing time key figure
- determination of power curves
  - ▶ power demand
  - ▶ power number (Newton number)
- influence of
  - ▶ stirrer type
  - ▶ geometric relationships
  - ▶ speed
  - ▶ substance properties (density, viscosity)
- evaluation of flow state by Reynolds' number (laminar, turbulent)
- mode of action of baffles
- gassing and heat exchange in stirred tanks
- observation of flow fields of different stirrer types for solutions, emulsions and suspensions

#### Description

##### ■ stirring machine with direct torque measurement to determine power curves

The mixing of solid, liquid and gaseous substances is necessary for the production of many products. The requirements in terms of the stirring machine vary considerably depending on the respective substances, so a large variety of different stirring machines are available.

The continuous phase is liquid during stirring. The CE 322 device can be used to study the production of solutions (solid dissolved in liquid), emulsions (mixture of insoluble liquids) and suspensions (insoluble solid in liquid).

The mixing process takes place in a stirred tank with coiled tube, baffles and gas distributor in the bottom. All installed components are removable.

The stirring machine is located above the stirred tank, can be lowered and is highly effective for the study of viscous substances. The speed can be adjusted. This makes it possible to undertake a detailed investigation of different stirrers and substances, including with gassing (recommendation: water, glycerine, compressed air).

Eleven different exchangeable stirrers are available. Plastic balls are used to visualise the characteristic flow fields of the different stirrer types.

Experiments on the influence of viscosity can be carried out with different substances or different temperatures. The baffles can be used to study and visualise the influence on the mixing process.

Sensors record electrical conductivity and temperature in the stirred tank. The mixing time and degree of mixing of solutions are determined using the electrical conductivities. Torque and speed are used for the power curves. The measured values are displayed digitally and can simultaneously be transmitted via USB directly to a PC, where they can be stored using the software included.

# CE 322

## Rheology and mixing quality in a stirred tank



1 stirring machine, 2 torque measurement, 3 electrical conductivity measurement, 4 temperature setting, 5 flow rate setting for gas, 6 coiled tube, 7 connections for hot and cold water and gas, 8 free connections for other measuring instruments

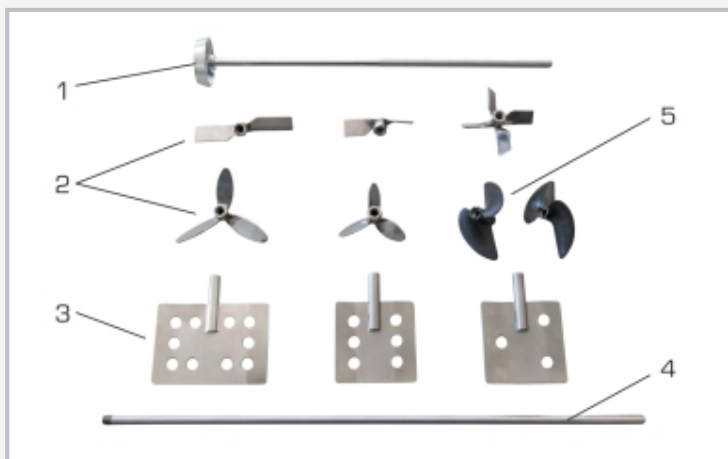

1 turbine stirrer, 2 pitched-blade stirrer, 3 blade stirrer, 4 threaded shaft, 5 propeller stirrer

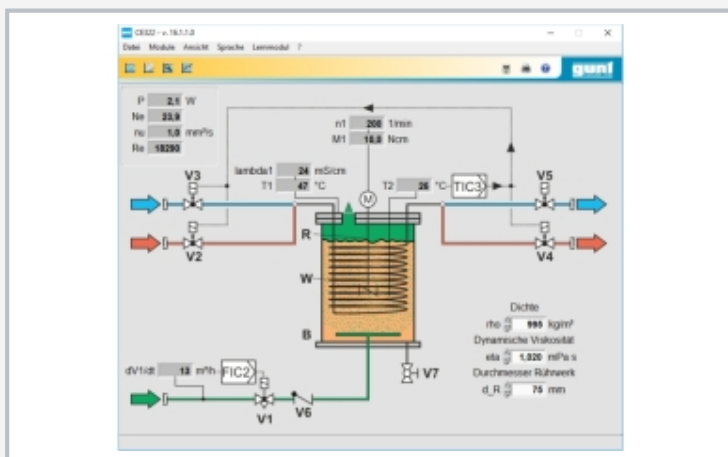

Software screenshot

### Specification

- [1] production of solutions, emulsions and suspensions with different viscosities
- [2] stirred tank with coiled tube, baffles and gas distributor in the bottom; removable components
- [3] lowerable, stirring machine with adjustable speed
- [4] 11 stirrers with different geometries
- [5] plastic balls to visualise flow fields
- [6] sensors and digital displays for electrical conductivity, temperature, speed, torque, flow rate
- [7] GUNT software for data acquisition via USB under Windows 10

### Technical data

#### Stirred tank

- volume: approx. 15L
- material: DURAN glass and PVC
- cover with 2 free connections for your own sensors
- gas distributor: holes  $\varnothing$  1,25mm

#### Stirrers

- 2 propeller stirrers
- 3 blade stirrers
- 5 pitched-blade stirrers
- 1 turbine stirrer

#### Coiled tube

- length: 9,4m,  $\varnothing$  140mm

#### Measuring ranges

- conductivity: 0...100mS/cm
- temperature: 0...100°C
- speed: 6...2000min<sup>-1</sup>
- torque: 0...200Ncm
- flow rate: 1...250L/min

230V, 50Hz, 1 phase

230V, 60Hz, 1 phase; 120V, 60Hz, 1 phase

UL/CSA optional

LxWxH: 800x500x1000mm (experimental unit)

LxWxH: 600x400x150mm (storage system)

Total weight: approx. 80kg

### Required for operation

cold and hot water connection, drain  
 compressed air (0...9m<sup>3</sup>/h, min. 3bar)  
 PC with Windows recommended

### Scope of delivery

- 1 experimental unit
- 1 GUNT software + USB cable
- 1 storage system
- 1 set of instructional material