

HM 170.70

Wind power plant with rotor blade adjustment



Network capable GUNT software: control and operation via 1 PC. Observation, acquisition, analysis of the experiments at any number of workstations via the customer's own LAN/WLAN network.

Description

- wind turbine with variable speed
- adjustable rotor blade and yaw angle
- determine the power coefficient tip-speed ratio characteristic diagram
- network capability: observe, acquire, analyse experiments via customer's own network

HM 170.70, together with the HM 170 wind tunnel, allows you to demonstrate a wind turbine with rotor blade pitching and variable-speed generator. The wind turbine is connected to the wind tunnel. The axial fan in the wind tunnel has a variable speed and provides the air flow required for the experiments. A flow straightener ensures consistent and low-turbulence flow. The generator is driven directly by a 3-blade rotor. A servo motor is used to change the angle of the rotor blades. The wind turbine stands on a tower.

In order to approach different operating points, the nominal speed of the generator can be set via a controller. The rotor speed is precisely measured by Hall sensors built into the generator. The wind velocity is measured by a horizontally adjustable sensor, so that the average wind velocity over the rotor surface can be recorded.

The measured values are transmitted via USB directly to a PC where they can be analysed using the GUNT software included. The GUNT software calculates the converted electrical power, the generator torque and system-specific parameters. Additionally, the network capable GUNT software makes it possible to observe, acquire, and analyse the experiments at any number of workstations via the customer's own network with just one licence.

The rotor blades can easily be replaced. Rotor blades with straight and with optimised profiles are included to allow you to investigate different shapes. Using suitable 3D design and printing processes, you can also use new rotor blade shapes you develop yourself.

The wind tunnel is closed during the experiments to ensure that the experiments are conducted safely. A transparent protective cover ensures safe operation.

Learning objectives/experiments

- conversion of kinetic energy into electrical energy
- power adjustment by means of
 - ▶ speed adjustment
 - ▶ rotor blade adjustment
- behaviour in the case of oblique flow
- recording of characteristic diagrams
- determination of the power coefficient
 - ▶ as a function of the tip-speed ratio and rotor blade adjustment angle
 - ▶ as a function of the tip-speed ratio and yaw angle
- comparison of different rotor blade shapes
- GUNT E-Learning
 - ▶ multi-media online course on the fundamentals of wind power
 - ▶ learning independent of time and place
 - ▶ access via Internet browser
 - ▶ check through targeted review of the learning objectives

HM 170.70

Wind power plant with rotor blade adjustment



1 connection for HM 170 wind tunnel, 2 flow straightener, 3 tower, 4 wind turbine, 5 protective cover

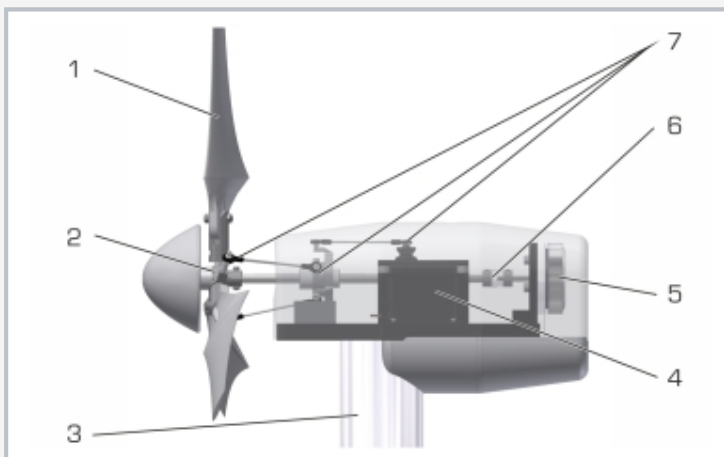

Wind turbine without spinner and nacelle casing
1 rotor blade, 2 rotor hub, 3 tower adapter, 4 servo motor, 5 generator, 6 generator coupling, 7 rotor blade pitching



Open wind tunnel HM 170 together with HM 170.70

Specification

- [1] wind turbine with adjustment of rotor blade and yaw angle
- [2] accessory for the HM 170 open wind tunnel
- [3] remote learning: detailed E-Learning course on the basics of wind power accessible online
- [4] gearless wind turbine with 3-blade rotor
- [5] variable speed generator system
- [6] power regulation by means of rotor blade pitching
- [7] interchangeable rotor blades with different shapes
- [8] option to investigate your own rotor blades (3D printing)
- [9] wind velocity, rotor speed and generated current are recorded by sensors
- [10] transparent protective cover for safe operation
- [11] control and operation via PC with GUNT software
- [12] network capability: observe, acquire, analyse experiments at any number of workstations with GUNT software via the customer's own LAN/WLAN network
- [13] GUNT software via USB under Windows 10

Technical data

Wind turbine

- rotor Ø: 0,3m
- number of rotor blades: 3
- rated electrical power: approx. 6W
- rated wind velocity: 10m/s
- rated speed: 2546min⁻¹
- weight: approx. 1,5kg
- nacelle: LxWxH: approx. 270x80x80mm

Generator

- rated voltage: 12V
- rated current: 2,02A

Rotor blades

- 3x straight rotor blade profile
- 3x optimised rotor blade profile

Measuring ranges

- wind velocity: 0,5...20m/s
- speed: 0...10000min⁻¹
- current: ±2,02A

230V, 50Hz, 1 phase, 230V, 60Hz, 1 phase
120V, 60Hz, 1 phase, UL/CSA optional
LxWxH: 1000x890x1540mm
Weight: approx. 95kg

Required for operation

PC with Windows

Scope of delivery

- 1 experimental unit
- 1 GUNT software + USB cable
- 1 set of instructional material

HM 170.70

Wind power plant with rotor blade adjustment

Required accessories

070.17000

HM 170

Open wind tunnel