

WP 950

Deformation of straight beams

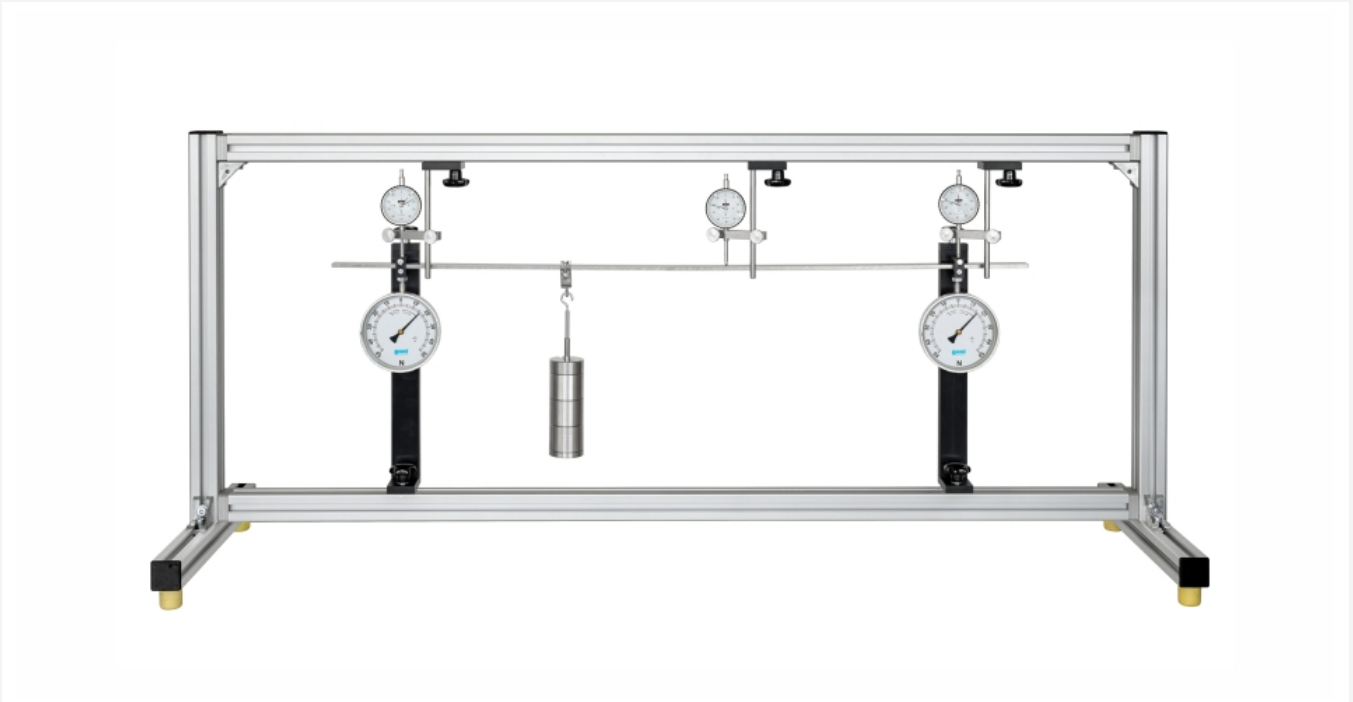

Description

- deformation of a beam on two or more supports under point loads (e.g. single-span beam)
- deformation of a cantilever beam under point loads
- statically determinate or indeterminate systems

Beams are key structural elements in mechanical engineering and in construction. A beam is a bar-shaped component in which the dimensions of the cross-section are much smaller than the length and which is subjected to load along and perpendicular to its longitudinal axis. The load perpendicular to the longitudinal axis causes a deformation of the beam – that is, bending. Based on its size, the beam is viewed as a one-dimensional model.

The science of the strength of materials deals with stress and strain resulting from the application of load to a component. Many fundamental principles of the strength of materials can be illustrated well by a straight beam.

The beam under investigation in WP 950 can be supported in different ways. This produces statically determinate and indeterminate systems which are placed under load by different weights.

The load application points are movable. Three dial gauges record the resulting deformation. Three articulated supports with integral force gauges indicate the support reactions directly. The articulated supports are height-adjustable, so as to compensate for the influence of the dead-weight of the beam under investigation. A fourth support clamps the beam in place.

Five beams of different thicknesses and made of different materials demonstrate the influence of the geometry and of the modulus of elasticity on the deformation of the beam under load.

The various elements of the experiment are clearly laid-out and housed securely in a storage system. The complete experimental setup is arranged in the frame.

Learning objectives/experiments

- investigation of the deflection for statically determinate and statically indeterminate straight beams
 - ▶ cantilever beam
 - ▶ single-span beam, dual- or triple-span beam
 - ▶ formulation of the differential equation for the elastic line
- deflection on a cantilever beam
 - ▶ measurement of deflection at the force application point
- deflection of a dual-span beam on three supports
 - ▶ measurement of the support reactions
 - ▶ measurement of the deformations
- influence of the material (modulus of elasticity) and the beam cross-section (geometry) on the elastic line
- Maxwell-Betti coefficients and law
- application of the principle of virtual work on statically determinate and indeterminate beams
- determination of lines of influence
 - ▶ arithmetically
 - ▶ qualitatively by way of force method (Müller-Breslau)

WP 950

Deformation of straight beams

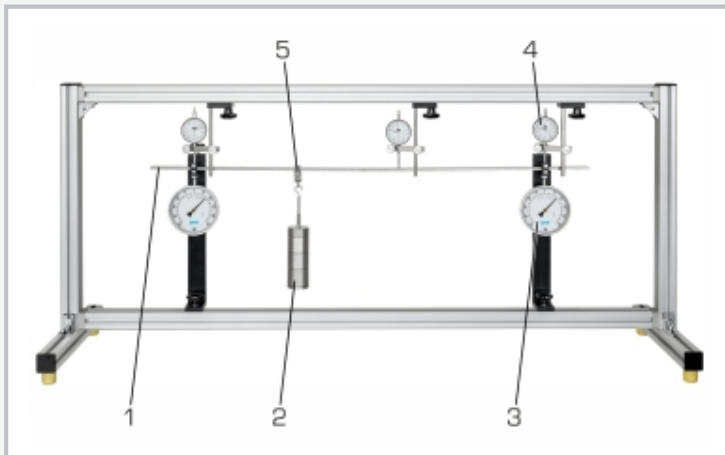

1 beam, 2 weight, 3 support with force gauge, 4 dial gauge, 5 adjustable hook

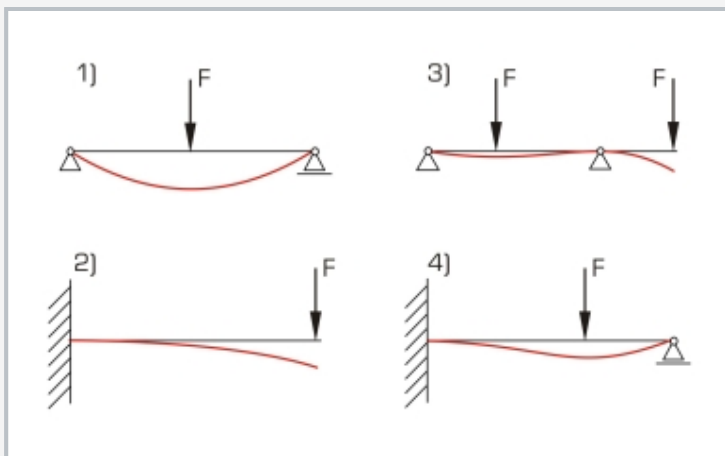

Elastic lines for statically determinate (left) and indeterminate (right) cases: 1 single-span beam with fixed and movable support, 2 cantilever, 3 beam with 2 fixed supports, 4 propped cantilever

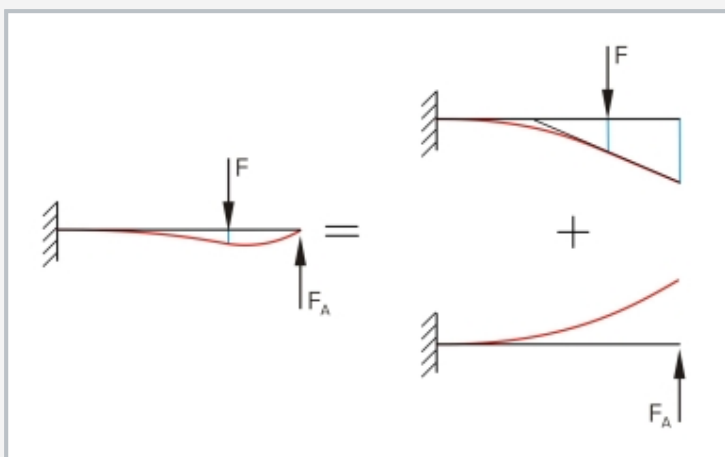

Superposition principle: the total elastic line of the statically indeterminate beam (left) is the sum of the deformations of the external force at the support (right)

Specification

- [1] elastic lines of statically determinate and indeterminate beams under various clamping conditions
- [2] 3 steel beams with different cross-sections
- [3] 1 brass and 1 aluminium beam
- [4] 3 articulated, height-adjustable supports with force gauge
- [5] 1 support with clamp fixing
- [6] force gauges can be zeroed
- [7] 3 dial gauges to record deformations
- [8] weights with adjustable hooks
- [9] anodised aluminium section frame housing the experiment
- [10] storage system to house the components

Technical data

Beam

- length: 1000mm
- cross-sections: 3x20mm (steel), 4x20mm (steel), 6x20mm (steel, brass, aluminium)

Frame opening: 1320x480mm

Weights

- 4x 2,5N (hanger)
- 4x 2,5N
- 16x 5N

Measuring ranges

- force: $\pm 50\text{N}$, graduation: 1N
- travel: 0...20mm, graduation: 0,01mm

LxWxH: 1400x400x630mm

Weight: approx. 37kg

LxWxH: 1170x480x178mm (storage system)

Weight: approx. 12kg (storage system)

Scope of delivery

- 1 frame
- 5 beams
- 4 supports
- 1 set of weights
- 3 dial gauges
- 1 set of accessories
- 1 storage system with foam inlay
- 1 set of instructional material

WP 950

Deformation of straight beams

Optional accessories

020.30009

WP 300.09

Laboratory trolley