

CE 225 Hydrocyclone



Learning objectives/experiments

- fundamental principle and the method of operation of a hydrocyclone
- solid mass flow rate in feed, overflow and underflow
- liquid mass flow rate in feed, overflow and underflow
- characteristic values for sharpness of separation
- pressure loss at the cyclone dependent on the feed flow rate
- influence of solids density on characteristic values and pressure loss

Description

- **solid separation with a hydrocyclone**
- **optimum observation of processes through transparent materials**
- **practical experiments on a laboratory scale**

Hydrocyclones can be used to separate solids suspended in liquids. In CE 225, the suspension is prepared in a tank. A pump delivers the suspension into the tangential inlet of the cyclone. In the cyclone a downward primary vortex is created. The downward taper causes the vortex to reverse. In the middle it moves as a secondary vortex back up towards the vortex finder, where the suspension emerges from the cyclone, having lost the coarse material in it. Inside the cyclone an air core is formed. The centrifugal forces cause the coarser solid particles in the primary vortex to be enriched.

They are discharged with the underflow at the apex nozzle. It is mainly the fine material that is discharged from the top.

The flow rate in the inlet is adjusted by a valve in a bypass and measured with an electromagnetic flow meter. Sampling points are installed at the underflow and overflow. The flow rates in them can be determined by means of a bucket and a stopwatch. To determine the solid concentration, a balance and a drying chamber are recommended. Using a suitable analysis device (such as a diffraction spectrometer), a separation function can be produced and the separation size determined. Quartz powder and diatomite are recommended for use as the solid.

The trainer was developed in cooperation with the **Department of Mechanical Process Engineering at Anhalt University of Applied Sciences**.

CE 225 Hydrocyclone

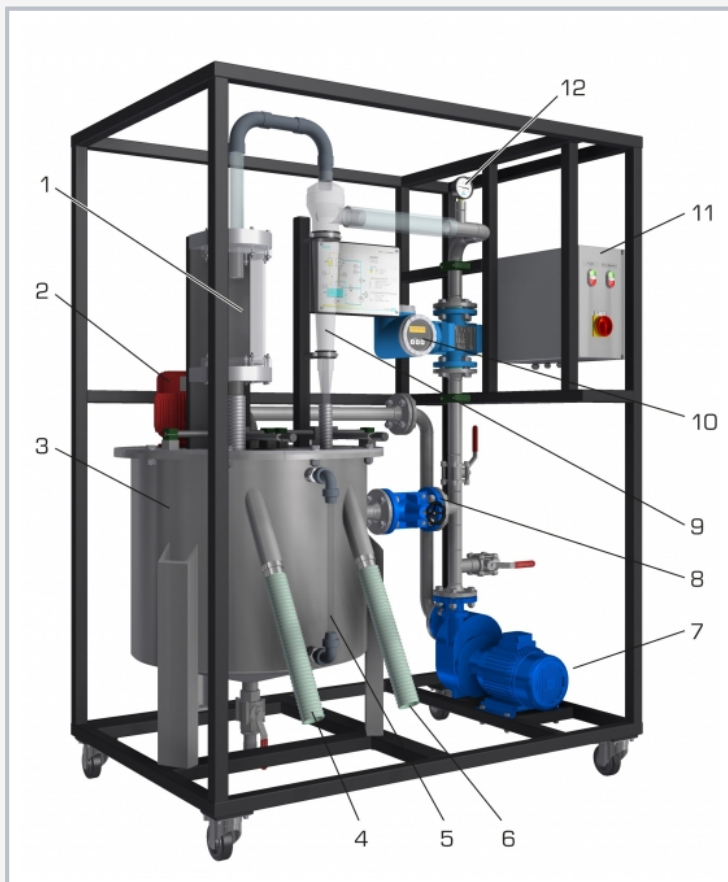

1 tank for observation of overflow, 2 stirring machine, 3 stirred tank, 4 overflow sampling point, 5 level indicator, 6 underflow sampling point, 7 pump, 8 valve in bypass, 9 hydrocyclone, 10 flow meter, 11 switch box, 12 manometer

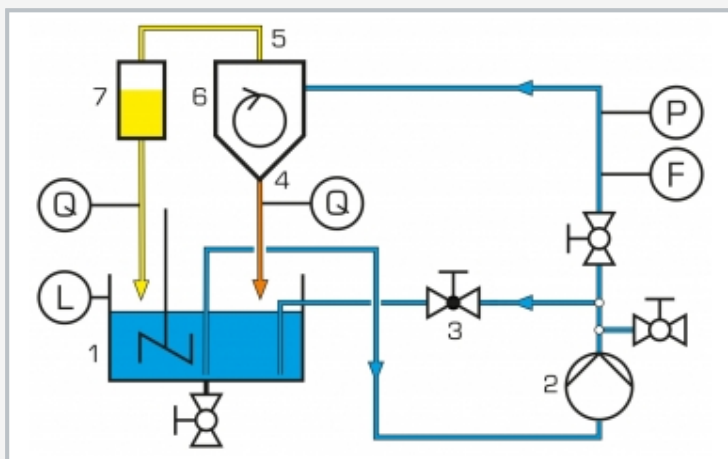

1 stirred tank, 2 pump, 3 valve in bypass, 4 underflow, 5 overflow, 6 hydrocyclone, 7 tank for observation of overflow;
F flow meter, P manometer, L level indicator, Q sampling point

Specification

- [1] solid separation from liquids with a hydrocyclone
- [2] hydrocyclone with tangential inlet
- [3] stirred tank for preparation of suspensions
- [4] centrifugal pump to deliver the suspension
- [5] adjustment of flow rate by valve in bypass
- [6] electromagnetic flow meter at inlet
- [7] sampling points on the overflow and underflow to determine the flow rates and solid concentrations
- [8] manometer to determine the pressure loss at the cyclone

Technical data

Cyclone

- height: 710mm
- \varnothing : 114mm
- vortex finder: \varnothing 40mm

Stirred tank

- capacity: 200L
- material: stainless steel

Overflow tank

- capacity: 5L
- material: PMMA

Pump

- max. flow rate: 400L/min
- max. head: 30m

Measuring ranges

pressure: 0...4bar
flow rate: 0...200L/min

400V, 50Hz, 3 phases
400V, 60Hz, 3 phases
230V, 60Hz, 3 phases
UL/CSA optional
LxWxH: 1500x1000x2020mm
Weight: approx. 370kg

Scope of delivery

- 1 trainer
- 7 apex nozzles
- 1 hose
- 2 buckets
- 1 measuring cup
- 1 shovel
- 1 stopwatch
- 1 set of tools
- 1 packing unit of quartz powder (25kg)
- 1 packing unit of diatomite (20kg)
- 1 set of instructional material