

# WL 315.01

## Shell & tube heat exchanger steam/water



### Learning objectives/experiments

- familiarisation with the heat transfer process between steam and water
- determine of heat flux of steam and water
- determine the efficiency or losses
- determine the overall heat transfer coefficient

### Description

- convective heat transfer between steam and water
- thermostatic steam regulation

Steam is particularly suitable as a heat transfer medium for heating fluids. The steam pressure can be used to limit the maximum temperature so that sensitive fluids can be heated safely. Tube bundles, for example, are used as heat exchangers. The steam condenses and transfers its condensation heat to the fluid being heated. The condensate can then be returned to the steam process.

The WL 315.01 trainer is used to study the convective heat transfer between steam and water. The core element of the trainer is a shell & tube heat exchanger. Heating steam in the pipe jacket and cold water in the pipes are directed past each other in counterflow.

In doing so, the heating steam emits some of its thermal energy to the cold water. The heated water flows into a tank, where it is available to be withdrawn.

In the steam pipe downstream of the shell & tube heat exchanger there is a condensate separator and a second, small heat exchanger as condenser for condensing the flash steam.

The amount of steam introduced is regulated by a thermostatic valve so that the water temperature in the hot water tank is at the desired temperature. Parallel to the thermostatic valve and shut-off valve, the heating steam can be manually directed into the shell & tube heat exchanger by means of a manual valve. The flow rate in the cold water circuit can be adjusted.

A strainer at the heating steam inlet protects against coarse particles in the steam pipes. The hot water tank is fitted with a safety valve to protect the system from positive pressure.

By measuring temperatures, pressures, flow rate and condensate quantity, it is possible to determine the energy, efficiency and overall heat transfer coefficient.

The heating steam is supplied by means of the accessory WL 315.02.

# WL 315.01

## Shell & tube heat exchanger steam/water

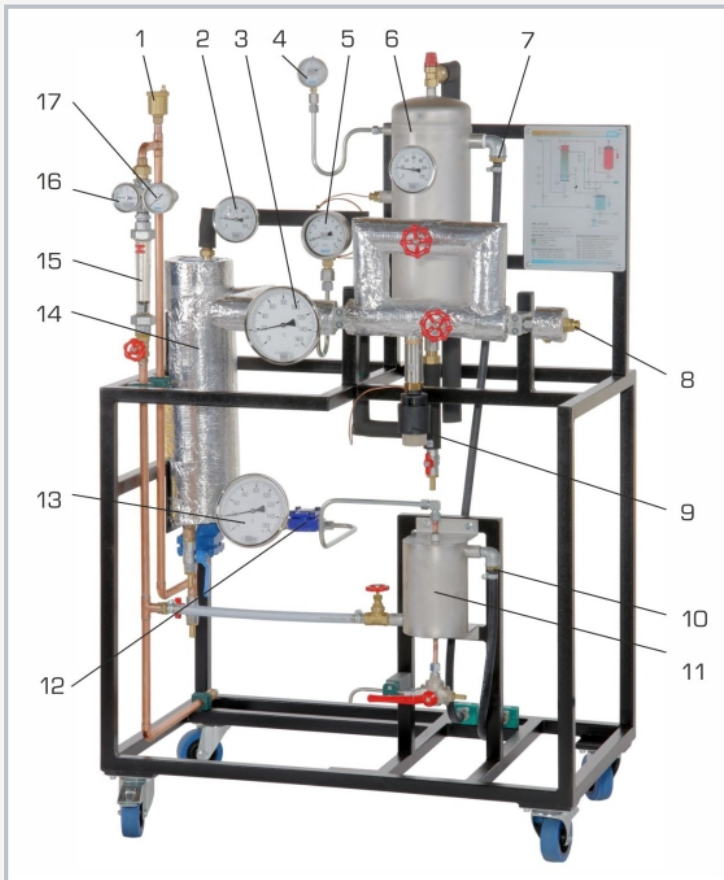

1 bleed valve in the cold water circuit, 2 hot water thermometer, 3 steam thermometer, 4 hot water manometer, 5 steam manometer, 6 hot water tank with thermometer and safety valve, 7 hot water extraction, 8 steam connection, 9 thermostatic valve, 10 cold water outlet, 11 condenser, 12 condensate separator, 13 steam thermometer downstream of condenser, 14 shell & tube heat exchanger, 15 flow meter, 16 cold water thermometer, 17 cold water manometer

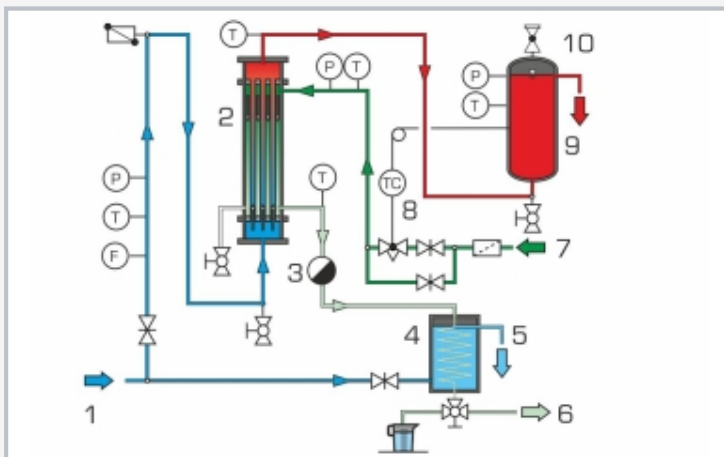

1 cold water inlet, 2 shell & tube heat exchanger, 3 condensate separator, 4 condenser, 5 cold water outlet, 6 condensate extraction, 7 steam inlet, 8 thermostatic valve, 9 hot water extraction, 10 hot water tank with safety valve; P pressure, T temperature, F flow rate, TC thermostat; blue: cold water, red: hot water, green: steam, light green: condensate, light blue: cooling water

### Specification

- [1] shell & tube heat exchanger for studying the convective heat transfer between steam and water in counterflow
- [2] steam volume controlled by thermostatic valve
- [3] additional manual valve for the introduction of heating steam into the shell & tube heat exchanger
- [4] precise determination of the steam volume by measuring the condensate volume
- [5] safety valve in the hot water tank for safe operation
- [6] measurement of temperatures, pressures, flow rate and condensate volume
- [7] supply with heating steam from WL 315.02

### Technical data

Shell & tube heat exchanger

- heat transfer surface: 0,178m<sup>2</sup>
- output: 14,6kW
- tubes 12x, stainless steel
  - ▶ Ø 12mm
  - ▶ length: 0,605m

Steam

- consumption: 13kg/h
- max. pressure saturated steam: 7bar

Steam control thermostat: 50...120°C

Measuring cup for condensate: 250mL

Measuring ranges

- flow rate: 40...400L/h
- temperature: 3x 0...120°C, 2x 0...160°C
- pressure: 1x -1...9bar, 2x 0...4bar

LxWxH: 1010x610x1630mm

Weight: approx. 85kg

### Required for operation

water connection, drain 400L/h  
steam 6kg/h, pressure: 3bar

### Scope of delivery

- 1 trainer
- 1 set of accessories
- 1 set of instructional material

# WL 315.01

## Shell & tube heat exchanger steam/water

Required accessories

060.31502      WL 315.02      Electrical steam generator 12kW