

TM 260.01

Rolling friction in friction wheels

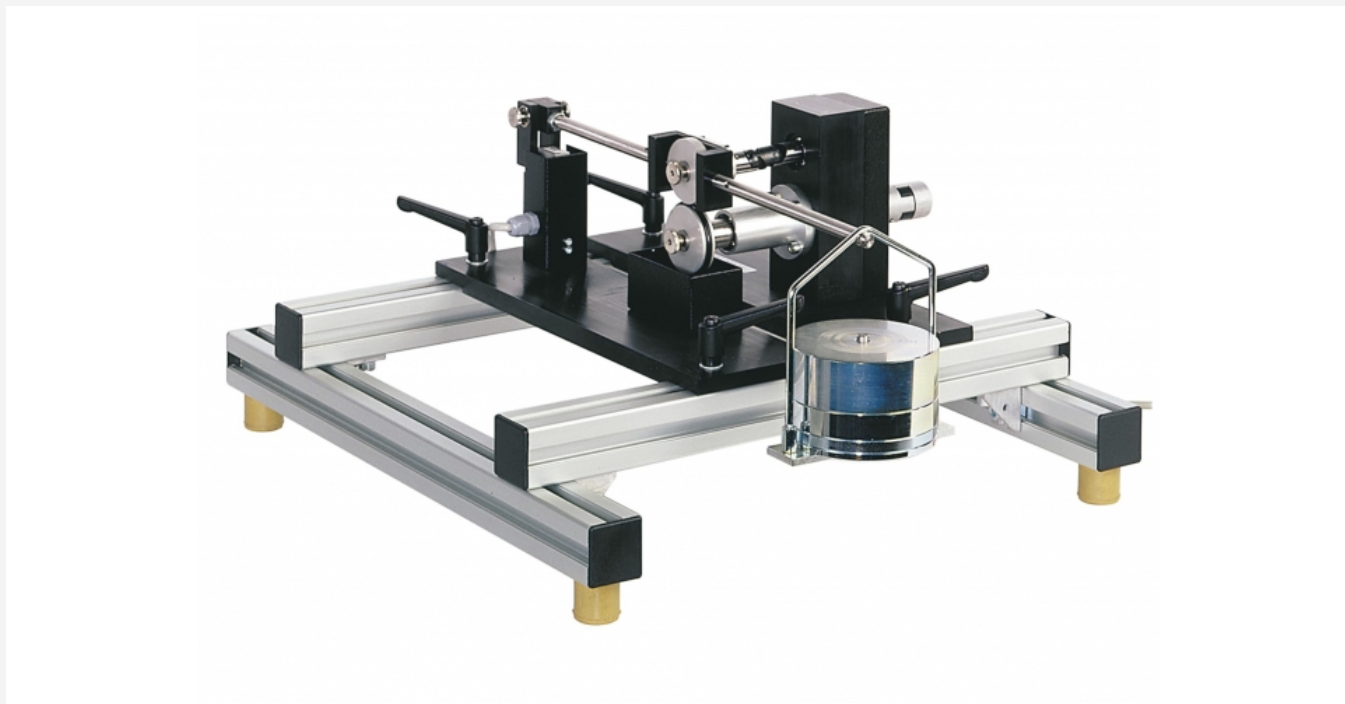

The illustration shows TM 260.01 on the TM 260 frame.

Description

- **frictional forces between two rolling friction wheels**
- **how slip affects the frictional force**
- **use of different lubricants possible**

In bearing and drive technology, dynamic friction occurs at the sliding and rolling points, which leads to power losses in the technical systems. Dynamic friction is differentiated into sliding, rolling and spinning friction. In dynamic friction, there is relative translation between the two bodies. Rolling friction occurs when two bodies roll on each other without sliding. In rolling friction, the rolling motion is superposed with a smaller sliding friction, known as slip. Rolling friction is therefore a combination of rolling and dynamic friction.

The tribological system in TM 260.01 allows a clear representation of the rolling friction and an analysis of the frictional forces. The experimental unit comprises two friction wheels, pairing the materials aluminium and rubber at the contact points.

The slip between the friction wheels is kept constant at 4% by a gear unit. The contact force can be adjusted gradually up to a maximum of 80 N by means of a lever. The experimental unit includes a tank that supplies lubricant. Different lubrication conditions can be studied, such as dry friction, water or oil lubrication.

The TM 260 drive unit is required in order to conduct experiments. The experimental unit is mounted quickly and easily on the frame of the drive unit with quick-action chucks. The driving wheel is driven by a clampable coupling between drive unit and gear unit. The display and control unit of the drive unit shows frictional force and speed and allows the continuous adjustment of the speed.

The frictional force and the coefficient of friction can be determined in experiments. The frictional forces are measured by a force sensor.

Learning objectives/experiments

- together with the drive unit
 - ▶ determine the frictional forces as a function of load, lubrication and operating speed
 - ▶ how slip affects the frictional force
 - ▶ determine the coefficients of friction

TM 260.01

Rolling friction in friction wheels

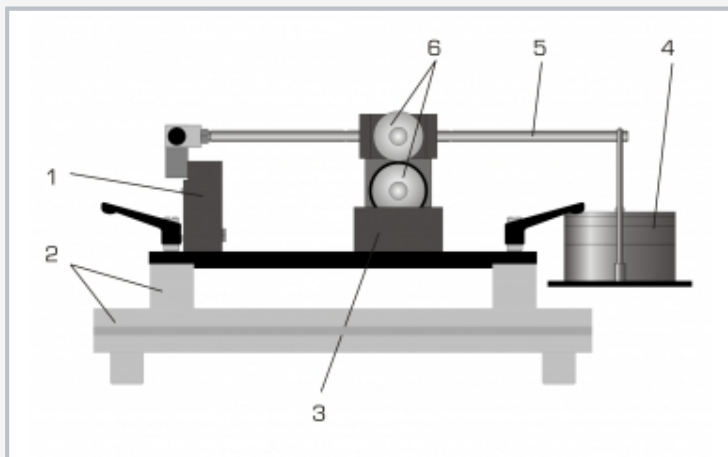

1 force sensor, 2 frame of TM 260, 3 tank for lubricant, 4 weight, 5 load application device lever, 6 friction wheels

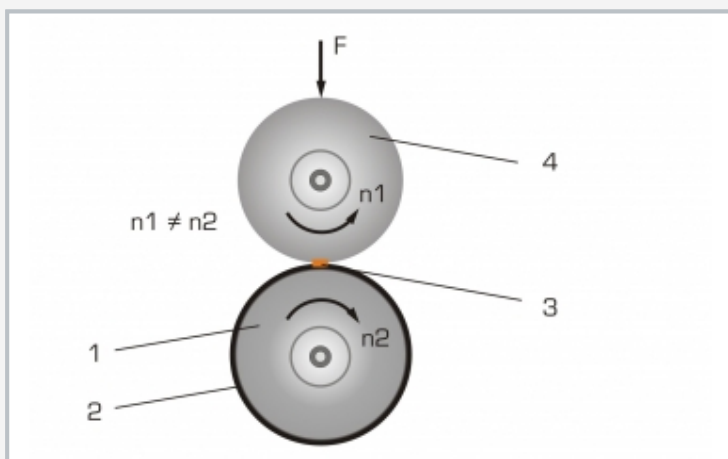

Tribological system using the example of friction wheels pairing aluminium and rubber:
1 driving friction wheel as main body, 2 rubber ring, 3 lubricant as intermediate substance, 4 driven wheel as counter body; F force, n speed

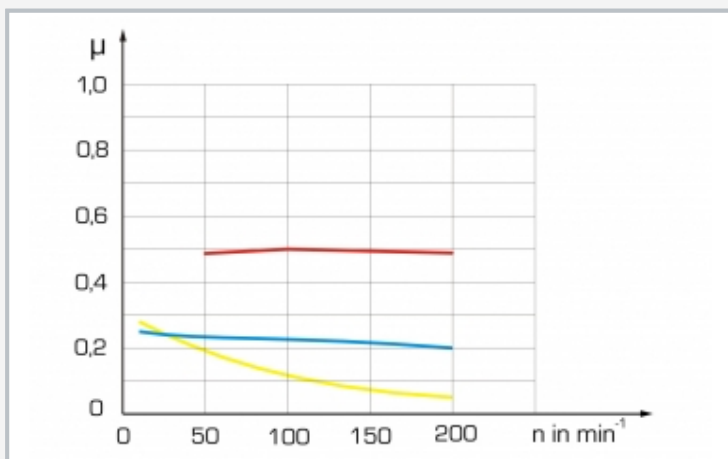

Coefficients of friction for different lubrication at constant load; μ coefficient of friction, n speed, red: dry friction, blue: water lubrication, yellow: oil lubrication

Specification

- [1] frictional forces in two rolling friction wheels
- [2] quick and easy assembly of the experimental unit on the frame of the drive unit
- [3] driving wheel is driven by a clampable coupling between drive unit and gear unit
- [4] slip between friction wheels kept constant at 4% by means of gear unit
- [5] load on the friction wheels via lever arm and stepped weights
- [6] friction wheels materials pair: aluminium/rubber
- [7] use of different lubricants
- [8] frictional force measured by force sensor
- [9] displays of force and speed and speed adjustment on the drive unit

Technical data

Load application device

- max. load: 80N
- lever arm ratio: 2:1

Friction wheels

- $\varnothing=49\text{mm}$
- $\varnothing=45\text{mm}$, incl. rubber ring

Gear ratio

- i: 0,96, slip approx. 23%

Force sensor for frictional force

- 0...50N

Weights

- 1x 5N (hanger)
- 1x 5N
- 1x 10N
- 1x 20N

LxWxH: 480x250x150mm

Weight: approx. 7kg

Scope of delivery

- 1 experimental unit
- 2 friction wheels
- 1 set of weights
- 1 set of instructional material

TM 260.01

Rolling friction in friction wheels

Required accessories

040.26000

TM 260

Drive unit for tribological investigations