

SE 110.47

Methods to determine the elastic line

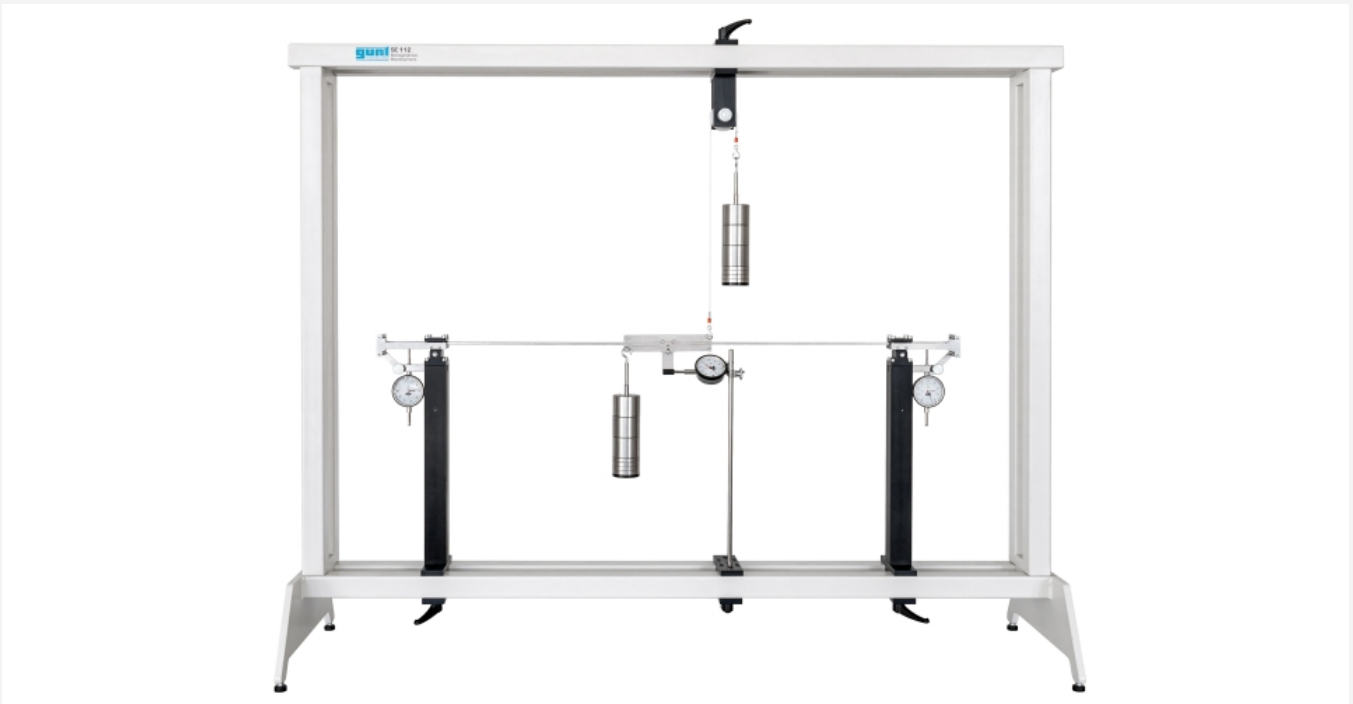

The illustration shows SE 110.47 in the mounting frame SE 112

Description

- **comparison of different methods to determine the elastic line: virtual work, Mohr's analogy**
- **statically determinate and indeterminate systems**
- **various load cases: point load or bending moment**

Beams are key structural elements in mechanical engineering and in construction which are subject to deformation under load. In the case of a simple beam this deformation can be predicted by various methods, such as the principle of virtual work.

The beam under investigation in SE 110.47 can be supported by different bearing methods. Two supports with clamp fixings and an articulated supports with a force gauge are provided to realise statically determinate or indeterminate systems. The two supports with clamp fixings are provided with dial gauges and can also be used as articulated supports. These dial gauges enable the angle of inclination of the beam to be determined at the support. A third dial gauge records the deflection of the beam at a random point.

A device is additionally provided to generate a bending moment at a random point on the beam. A fourth dial gauge records the angle of inclination of the device.

The beam is placed under load by weights (point load and coupled forces to generate the bending moment). The clamping moment on the supports can be determined by means of weights.

The various elements of the experiment are clearly laid-out and housed securely in a storage system. The complete experimental setup is arranged in the frame SE 112.

Learning objectives/experiments

- elastic lines for statically determinate or indeterminate beams under load
- determination of the elastic line of a beam by
 - ▶ the principle of virtual work (calculation)
 - ▶ Mohr's analogy (area moment method devised by Mohr; graphical representation)
- application of the principle of superposition
- determination of the
 - ▶ maximum deflection of the beam
 - ▶ angle of inclination of the beam
- comparison between calculated and measured values for angle of inclination and deflection

SE 110.47

Methods to determine the elastic line

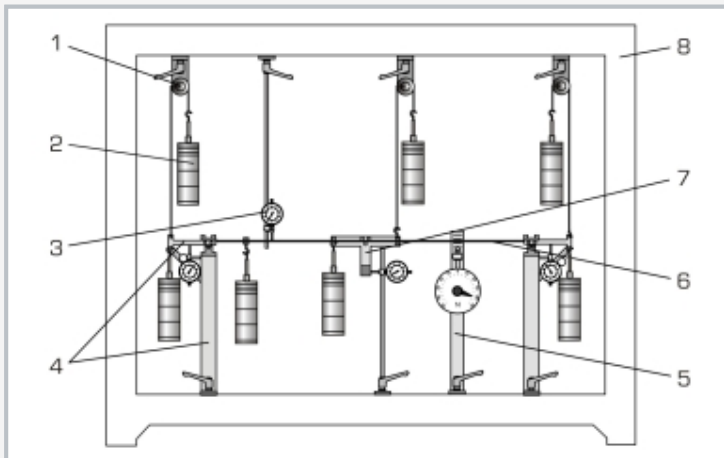

1 deflection roller with fixture, 2 weight, 3 dial gauge, 4 support with clamp fixing and dial gauge, 5 support with force gauge, 6 beam, 7 device to generate the bending moment, 8 frame SE 112

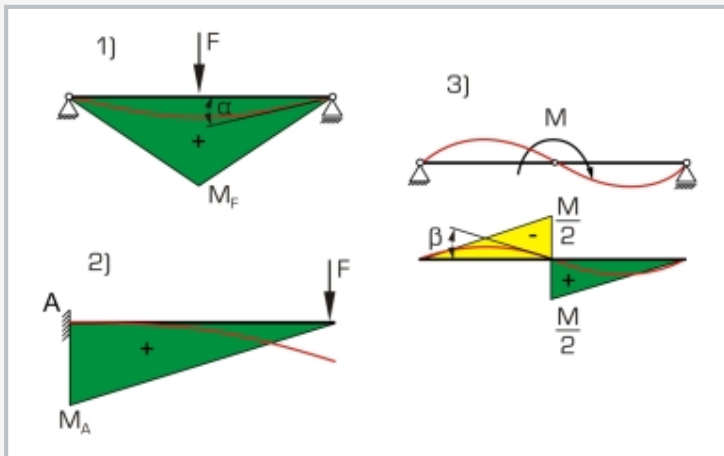

Bending moment characteristic (green/yellow) and elastic line (red) for statically determinate beams: 1) single-span beam with mid point load, 2) cantilever beam with point load, 3) single-span beam with bending moment as load; M_A bending moment on support A, M_F bending moment resulting from force F, M bending moment, α , β angle of inclination

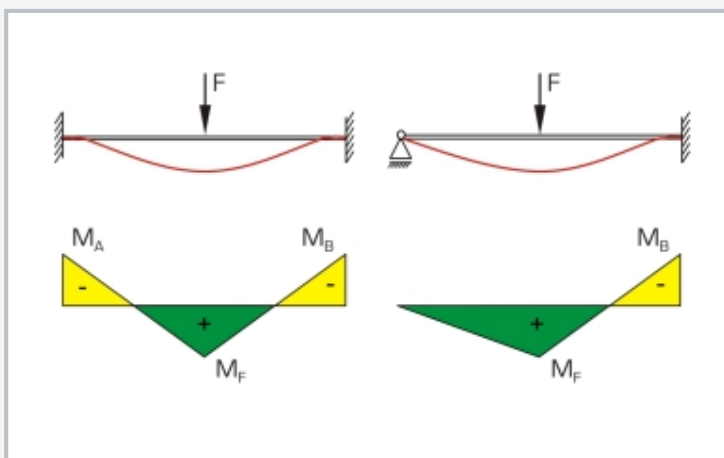

Bending moment characteristic (green/yellow) and elastic line (red) for statically indeterminate beams with centralised point load

Specification

- [1] comparison of different methods to determine the elastic line
- [2] statically determinate or indeterminate beam
- [3] 2 supports with clamp fixing, optionally as articulated support with measurement of angle of inclination or clamp fixing
- [4] 1 articulated support with force gauge
- [5] device to generate a bending moment
- [6] dial gauge with generation of moment to measure the angle of inclination
- [7] dial gauge to record the deformations of the beam
- [8] weights to subject the beam to point loads or moment
- [9] weights to determine the clamping moments on the supports with clamp fixings
- [10] storage system to house the components
- [11] experimental setup in frame SE 112

Technical data

Beam

- length: 1000mm
- cross-section: 20x4mm
- material: steel

Weights

- 7x 1N (hanger)
- 28x 1N
- 21x 5N

Measuring ranges

- force: $\pm 50\text{N}$, graduation: 1N
- travel: 0...20mm, graduation: 0,01mm

LxWxH: 1170x480x178mm (storage system)

Weight: approx. 42kg (total)

Required for operation

Mounting frame SE 112

Scope of delivery

- 3 beams
- 2 supports with clamp fixings
- 1 support with force gauge
- 1 device to generate the bending moment
- 1 set of weights
- 3 deflection rollers with fixture
- 3 cables
- 2 dial gauges with bracket
- 1 storage system with foam inlay
- 1 set of instructional material

SE 110.47

Methods to determine the elastic line

Required accessories

022.11200	SE 112	Mounting frame
-----------	--------	----------------

Optional accessories

022.11030	SE 110.30	Dial gauges
-----------	-----------	-------------