

SE 110.19

Investigation of simple stability problems



The illustration shows SE 110.19 in the frame SE 112

Description

- representation of simple stability problems on a buckling bar
- determination of the buckling load under different conditions
- continuously variable load application on the buckling bar

Buckling is a stability problem which occurs in practice when slim components are subjected to compressive loading. Following a "disturbance" to its equilibrium, such as caused by compressive loading, a stable system returns to equilibrium when the loading is removed. If the compressive load increases excessively, instability of the system results. The component buckles and fails. The critical compressive load at which the system becomes unstable is termed the buckling force.

A simple model for representing stability problems is a two-part bar with an elastic joint which remains stable up to a certain load level. If the buckling force is exceeded, the bar suddenly buckles and so becomes unstable.

SE 110.19 is used to investigate simple stability problems on a buckling bar under different conditions. The buckling bar is in two parts, with a central articulated joint. A compressive load is applied to the bar by a lever and weights.

The continuously variable loading is determined precisely with the aid of a scale on the load application lever.

Experiments can depict a variety of conditions, such as an elastic joint or an elastic clamp fixing. Two tension springs serve as the elastic joint. For the elastic clamp fixing option, a steel leaf spring is mounted in the bottom joint. The variable length of the leaf spring means various degrees of clamping are possible. The two cases can be combined.

Another experiment demonstrates the influence of additional shear forces. It involves applying a shear force to the joint in the buckling bar with a cable and a weight.

In all experiments the buckling bar is placed under load until it reaches an unstable situation. The length of the lever arm at which the buckling bar buckles is read from the scale and the buckling force is then determined.

All the component elements of the experiment are clearly laid-out and housed securely in a storage system. The complete experimental setup is arranged in the frame SE 112.

Learning objectives/experiments

- determination of the buckling force for the case of an:
 - ▶ elastic joint
 - ▶ elastic fixed end support
- investigation of the buckling behaviour under the influence of:
 - ▶ of additional shear forces
 - ▶ of pre-deformation

SE 110.19

Investigation of simple stability problems

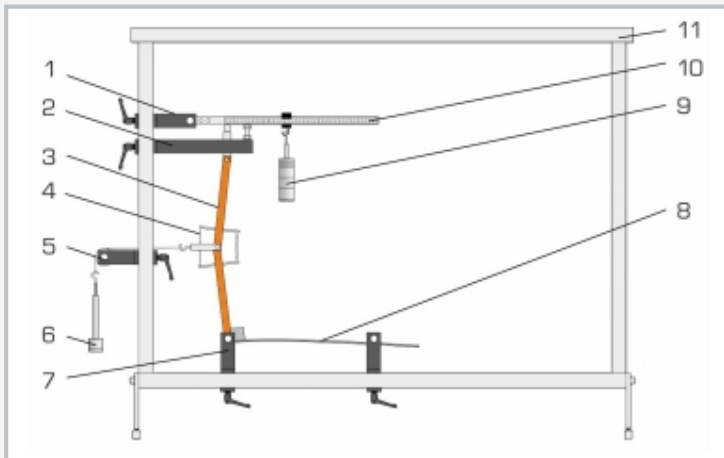

1 articulated support, 2 support with pressure pad and stop screw, 3 buckling bar, 4 articulated spring, 5 deflection roller, 6 weight, 7 articulated support, 8 leaf spring, 9 weight, 10 load application lever with scale, 11 frame SE 112

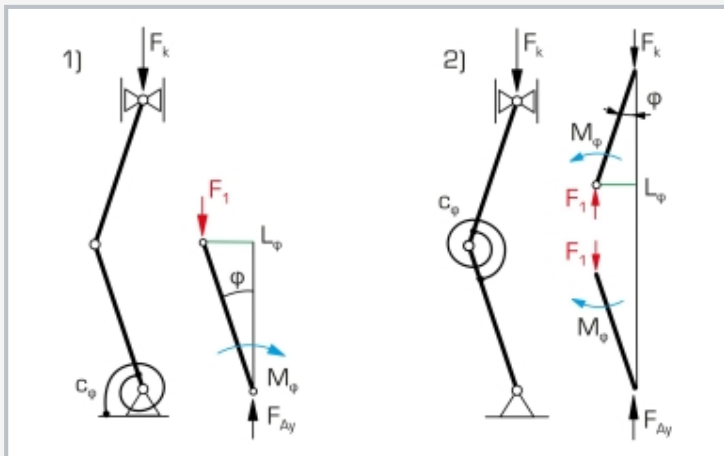

1) experimental setup for elastic support
 2) experimental setup for elastic joint;
 F_k buckling force, F_1 articulation force, F_{Ay} support reaction, M_φ internal bending moment, L_φ deflection, c_φ torsional rigidity, φ deflection angle

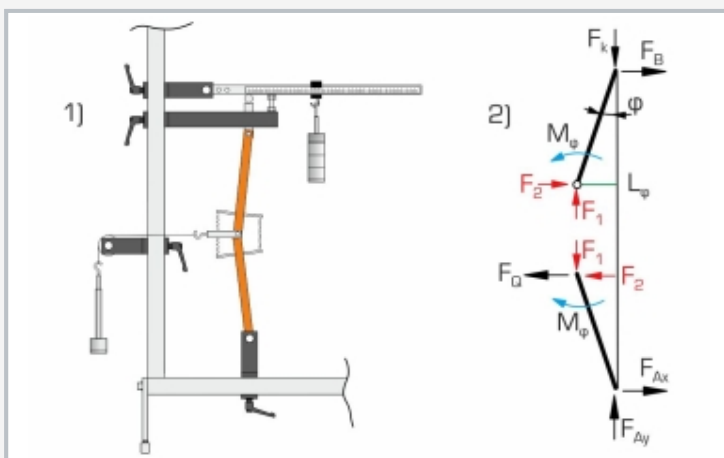

1) experimental setup for elastic joint with transverse loading
 2) free-body diagram; F_D shear force, F_B and F_A support reactions, M_φ internal bending moment, L_φ deflection, φ deflection angle, F_k buckling force, F_1 articulation force, F_2 cable force

Specification

- [1] investigation of the buckling load under different conditions (elastic joint, elastic fixed end)
- [2] two-part buckling bar with central joint
- [3] loading continuously variable with lever and weights
- [4] determination of loading via scale on load application lever
- [5] various degrees of clamping via leaf spring with variable length on bottom support
- [6] thrust pad guided friction-free inside spherical shell
- [7] low-friction joints with roller bearings
- [8] device to generate shear forces
- [9] storage system to house the components
- [10] experimental setup in frame SE 112

Technical data

Two-part buckling bar with central joint

- $W \times H$: 20x20mm
- length: 2x250mm
- support: pinned-pinned (articulated-articulated)

Elastic joint

- 2 tension springs, rigidity: 2N/mm
- lever arm: 50mm

Elastic clamp fixing with steel leaf spring

- length: 500mm
- cross-section: 10x2mm
- second moment of area: 6,66mm⁴
- modulus of elasticity: 205000N/mm²

Compressive force range: 25...120N

Shear force: 0...20N

Load application lever, lever ratio: 1:2...1:5

Weights

- 2x 1N (hanger)
- 8x 1N
- 6x 5N

$L \times W \times H$: 1170x480x178mm (storage system)

Weight: approx. 28kg (total)

Required for operation

Mounting frame SE 112

Scope of delivery

- 1 buckling bar, two-part
- 1 set of weights
- 4 supports
- 1 deflection roller
- 1 load application lever
- 1 leaf spring
- 2 tension springs
- 1 cord
- 1 hexagon socket wrench
- 1 storage system with foam inlay
- 1 set of instructional material

SE 110.19

Investigation of simple stability problems

Required accessories

022.11200

SE 112

Mounting frame