

SE 110.14

Elastic line of a beam



The illustration shows SE 110.14 in the SE 112 mounting frame

Description

■ **beams of different materials:
steel, brass and aluminium**

Beams are important design elements in mechanical engineering and building construction that can deform under load. Beams are subjected to load transversely in the axial direction, which leads to deflection. In linear-elastic material behaviour, the bending line, also known as elastic line, is used to determine the deflection of beams. Deflection can be determined at any point on the beam using the influence coefficients and Maxwell-Betti's commutative theory.

The SE 110.14 unit is used to determine the deformation of a bending beam. To do this, a beam is studied under varying loads, different support conditions and static indeterminacy. The elastic line is determined by calculation and verified by experiment.

The experimental setup includes three beams made of different materials. Two articulated supports and one fixed support with clamp are available. The dial gauges record the resulting deformation of the beam. The parts of the experiment are clearly laid out and securely housed in a storage system.

The entire experimental setup is constructed in the SE 112 mounting frame.

Learning objectives/experiments

- elastic line under varying load
- elastic line under various support conditions
- demonstration of Maxwell-Betti's theorem
- elastic line in statically indeterminate systems

SE 110.14

Elastic line of a beam

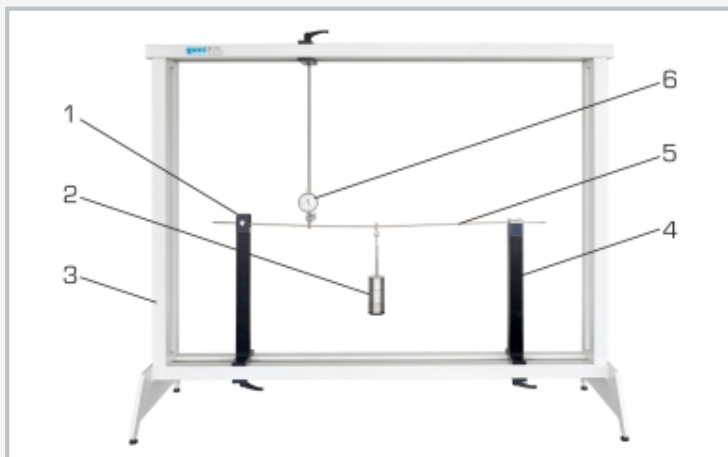

Elastic line in statically indeterminate systems:
 1 articulated support, 2 weight, 3 SE 112 frame, 4 fixed support with clamp, 5 beam, 6 dial gauge

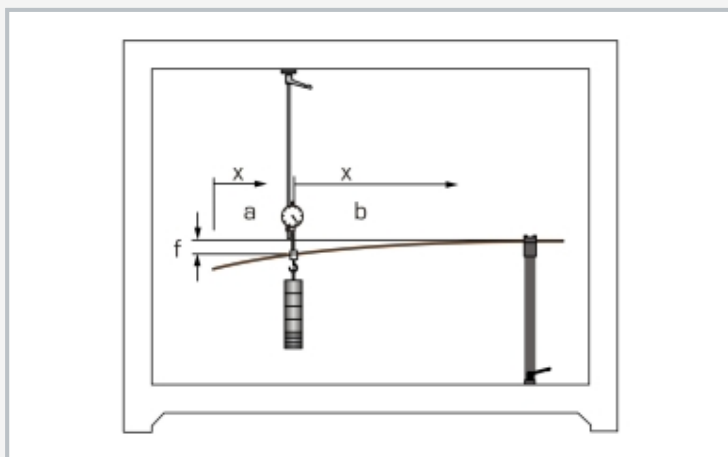

Bending on a cantilever beam: f draw down of the beam's end, x distance, a unloaded region with linear elastic line, b loaded region

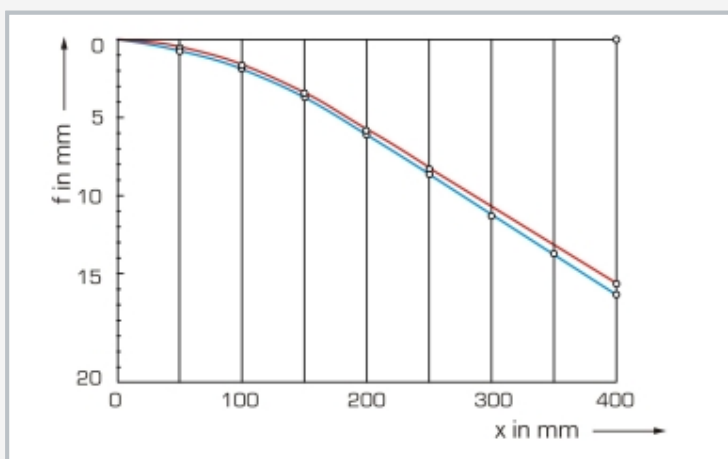

Elastic line of a cantilever beam: f draw down, x distance; red: calculated values, blue: measured values

Specification

- [1] determine the elastic line
- [2] beams of different materials: steel, brass and aluminium
- [3] 2 articulated supports
- [4] 1 fixed support with clamp
- [5] dial gauges for recording the deformation of the beam
- [6] storage system for parts
- [7] experiment setup in the SE 112 mounting frame

Technical data

Beams

- steel, LxWxH: 1000x20x3mm
- brass, LxWxH: 1000x20x6mm
- aluminium, LxWxH: 1000x20x6mm

Weights

- 2x 1N (hanger)
- 10x 1N
- 6x 5N

Measuring ranges

- travel: 0...20mm
- graduation: 0,01mm

LxWxH: 1170x480x178mm (storage system)

Weight: approx. 42kg (total)

Required for operation

Mounting frame SE 112

Scope of delivery

- 3 beams
- 2 articulated supports
- 1 fixed support with clamp
- 2 dial gauges with bracket
- 1 set of weights
- 1 storage system with foam inlay
- 1 set of instructional material

SE 110.14

Elastic line of a beam

Required accessories

022.11200	SE 112	Mounting frame
-----------	--------	----------------

Optional accessories

022.11030	SE 110.30	Dial gauges
-----------	-----------	-------------