

# RT 682

## Multivariable control: stirred tank



### Learning objectives/experiments

- coupled level and temperature control
- level control with
  - ▶ PI controller
  - ▶ feedforward control
- temperature control
  - ▶ with two-point controller
  - ▶ with three-point controller (split range)
  - ▶ with override control
  - ▶ via motorised valve with position feedback
- plotting step responses



### Description

- **practical multivariable control of temperature and level in a stirred tank**
- **typical application from process engineering with heat recovery**
- **two configurable industrial controllers**
- **optional process control software RT 650.60 available**

With RT 682 the complexities of a multivariable control system can be learned in a practical manner. The model for the controlled process is a typical application from process engineering: A chemical reaction taking place in a heated stirred tank. The reactants entering the stirred tank are pre-heated by the out-flowing products in order to enhance energy efficiency.

Water is used as the product and reactant for RT 682. A pump transports the reactant out of a collecting tank via a heat exchanger into the stirred tank. The reactant is pre-heated by the heat exchanger. A heater in the double jacket permits control of the temperature in the stirred tank. Another pump transports the heated product out of the stirred tank via the heat exchanger back into the collecting tank. A bypass in the inlet routes the flow past the heat exchanger. A three-way motorised valve adjusts the ratio between the flow heated in the heat exchanger and the flow in the bypass. This is a further method of controlling the temperature in the stirred tank. A control valve changes the flow rate in the outlet and thus the level in the stirred tank. The temperature and level are mutually dependent variables. It is this dependence that makes this multivariable control system so complex.

Two industrial controllers are provided as temperature and level controllers. They can be configured and parameterised using a supplied software. The controllers have a PROFIBUS DP interface. The interface permits monitoring of the trainer via an optionally available software RT 650.60. The RT 650.60 software also permits recording of the process variables and parameterisation of the controllers using the PC. It is also possible to interconnect multiple trainers from this series through the PROFIBUS DP interface.

# RT 682

## Multivariable control: stirred tank

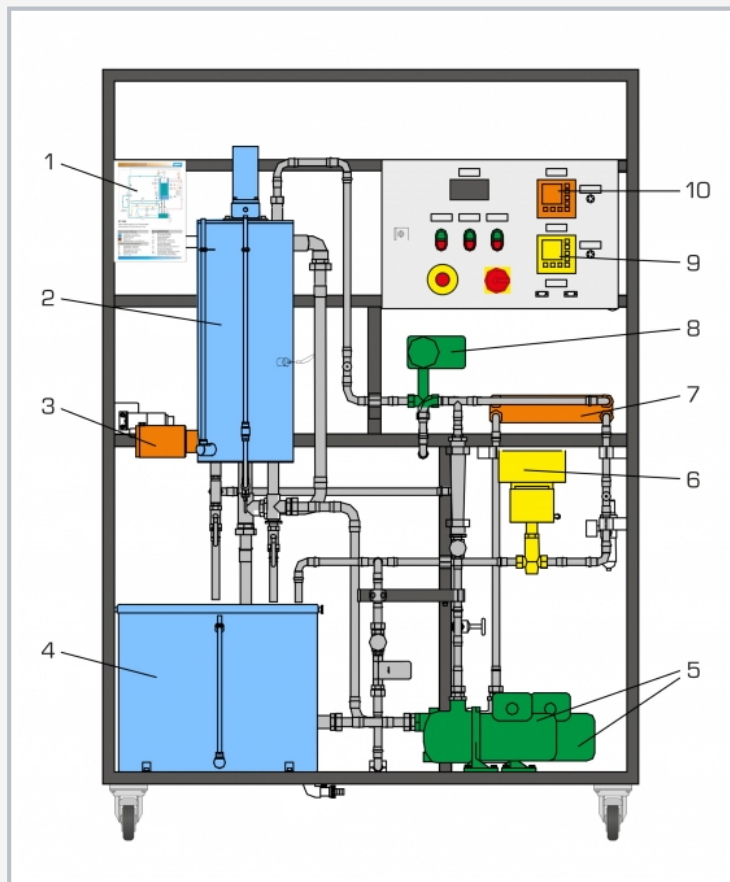

1 process schematic, 2 stirred tank, 3 heater, 4 collecting tank, 5 pumps, 6 level control valve, 7 heat exchanger, 8 3-way motorised valve, 9 level controller, 10 temperature controller

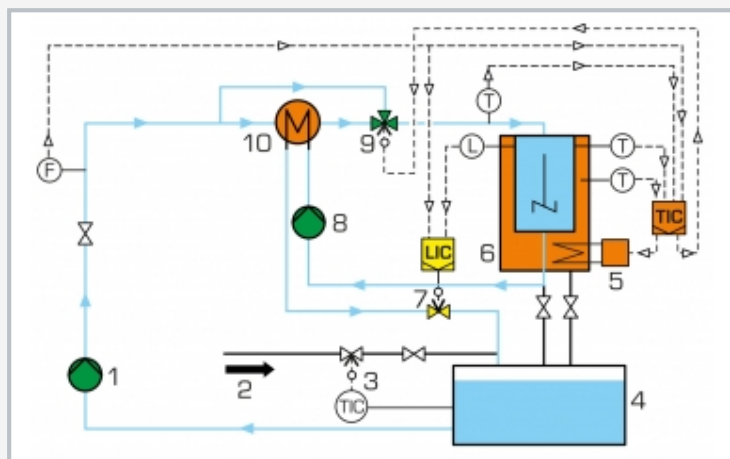

1 main circuit pump, 2 external cooling water, 3 collecting tank temperature control, 4 collecting tank, 5 heater, 6 stirred tank, 7 level control valve, 8 pre-heating pump, 9 3-way motorised valve, 10 heat exchanger; F flow rate, T temperature, L level, LIC controller (level), TIC controller (temperature)

### Specification

- [1] coupled level and temperature control in one stirred tank
- [2] circuit with stirred tank, collecting tank and pump
- [3] heat recovery with heat exchanger
- [4] stirred tank with double jacket and heater; level display for tank and jacket
- [5] temperature control with heater and 3-way motorised valve as actuators
- [6] level control with pneumatic control valve as actuator
- [7] temperature controller and level controller configurable and parameterisable with software
- [8] 2-point controller for constant temperature in collecting tank via external cooling water
- [9] optional process control software RT 650.60 via PROFIBUS DP interface

### Technical data

#### Tanks

- stirred tank: 15L
- collecting tank: 70L

#### 2 pumps

- max. flow rate: approx. 60L/min
- max. head: approx. 20m

Heat exchanger transfer surface: approx. 0,8m<sup>2</sup>

Heater power output: approx. 2kW

Temperature and level controller parameterisable as

- P, PI or PID controller
- switching controller

#### Measuring ranges

- flow rate: 60...640L/h
- temperature: 0...100°C
- level: 0...1000mm
- 3-way motorised valve opening: 0...100%

230V, 50Hz, 1 phase

230V, 60Hz, 1 phase; 230V, 60Hz, 3 phases

UL/CSA optional

LxWxH: 1360x610x1940mm

Weight: approx. 162kg

### Required for operation

water connection: min. 60L/h

compressed air connection: 3...10bar

### Scope of delivery

- 1 trainer
- 1 set of cables
- 1 set of hoses
- 1 CD with software for parameterisation and configuration of the controllers
- 1 set of instructional material

## **RT 682**

### **Multivariable control: stirred tank**

Optional accessories

080.65060

RT 650.60

Process control software for RT 681 and RT 682