

RT 674

Flow / level control demonstration unit



Learning objectives/experiments

- fundamentals of control engineering
- latest industrial control engineering components: controllers, transducers, actuators
- operation and parameter setting of a multifunctional state-of-the-art digital controller: e.g. parameter setting as P, PI and PID controller
- investigation of disturbance and control response
- influence of different controller parameters on stability and control quality
- investigation of the properties of the open and closed control loops
- processing of process variables using external equipment, e.g. plotter or oscilloscope
- investigating the response of the various controlled systems
- control of
 - ▶ flow rate
 - ▶ level
 - ▶ level via flow rate (cascade)
- together with accessory RT 650.40: familiarisation with and use of I&C software

Description

- experimental introduction to control engineering using an example of flow and / or level control
- two controllers permit control in cascade mode
- construction of the system with components commonly used in industry
- digital controllers with freely selectable parameters: P, I, D and all combinations
- optional I&C software RT 650.40 via USB

The experimental unit provides a comprehensive experimental introduction to the fundamentals of control engineering using an example of combined flow and level control. The level and flow rate can be controlled individually and as a cascade. In cascade mode the level is the primary controlled variable.

The flow control then provides optimum adjustment of the controlled variable to the reference variable (set value).

All components are clearly laid out on a vertical panel. The large-format process scheme provides an aid to understanding. A pump delivers water from a storage tank into a piping system which contains a rotameter. From there the water passes into the transparent level-controlled tank. The level is measured by a pressure sensor installed at the base of the level-controlled tank. The controllers used are two state-of-the-art digital industrial controller. The actuator in the control loop is an electromagnetic proportional valve. Ball valves in the tank outlet and in the pipe system enable defined disturbance variables to be generated. The controlled variable X and the manipulating variable Y can be tapped as analogue signals at lab jacks.

This enables external recording equipment, such as a plotter or an oscilloscope, to be connected.

An instrumentation and control software (RT 650.40) with interface module (USB) is available as an accessory. This enables the key process variables to be represented, and control functions executed.

RT 674

Flow / level control demonstration unit



1 controller, 2 control valve, 3 rotameter with electrical output, 4 pump, 5 storage tank, 6 pressure sensor for level measurement, 7 level-controlled tank with overflow

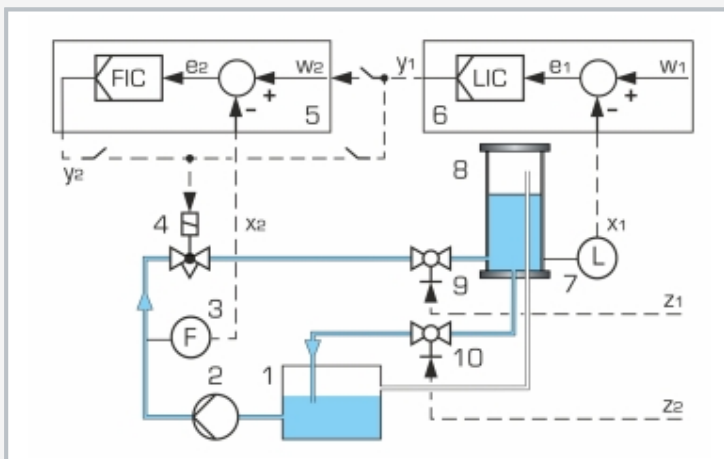

1 storage tank, 2 pump, 3 measuring element: flow rate sensor, 4 actuator: control valve, 5, 6 digital industrial controllers, 7 measuring element: pressure sensor for level measurement, 8 level-controlled tank, 9, 10 generate disturbance variables via ball valves; x1 controlled variable: level, x2 controlled variable: flow rate, y1, y2 manipulated variable: degree of opening of control valve, z1, z2 disturbance variable: degree of opening of ball valves, w1, w2 reference variable: input values, e1, e2 control deviation, F flow rate, L level

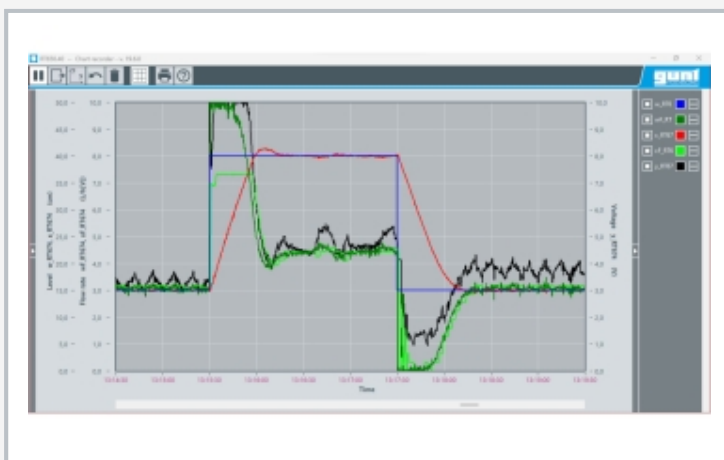

Screenshot of optional I&C software RT 650.40

Specification

- [1] experimental unit for control engineering experiments
- [2] level and flow control individually, and cascaded
- [3] level measurement by pressure sensor
- [4] flow rate measurement by rotameter with electrical output
- [5] generation of disturbance variables by ball valves with scale
- [6] tank with overflow and scale
- [7] control valve: electromagnetic proportional valve
- [8] 2 digital industrial controllers, parameterisable as P, PI or PID controllers, cascade
- [9] large process schematic on front panel
- [10] key process variables accessible as analogue signals at lab jacks

Technical data

Storage tank

- stainless steel
- capacity: 15L

Pump, 3-stage

- power consumption: 90W
- max. flow rate: 83L/min
- max. head: 6m

Pressure sensor for level measurement: 0...100mbar

Rotameter with electrical output: 0...600L/h

Electromagnetic proportional valve: $Kvs: 1,1 \text{ m}^3/\text{h}$

2x controllers: parameterisable as P, PI or PID controller

Process variables as analogue signals: 0...10V

Connection of external recording devices (e.g. oscilloscope, line recorder) via lab jacks

230V, 50Hz, 1 phase

230V, 60Hz, 1 phase

120V, 60Hz, 1 phase

UL/CSA optional

LxWxH: 1000x500x1080mm

Weight: approx. 73kg

Scope of delivery

- 1 experimental unit
- 1 set of laboratory cables
- 1 set of instructional material

RT 674

Flow / level control demonstration unit

Optional accessories

080.65040	RT 650.40	I&C software for RT 614 - RT 674 series
020.30009	WP 300.09	Laboratory trolley