

RT 644

Temperature control demonstration unit



Learning objectives/experiments

- fundamentals of control engineering
- latest industrial control engineering components: controllers, transducers, actuators
- operation and parameter setting of a multifunctional state-of-the-art digital controller: e.g. parameter setting as P, PI and PID controller
- investigation of disturbance and control response
- influence of different controller parameters on stability and control quality
- investigation of the properties of the open and closed control loops
- processing of process variables using external equipment, e.g. plotter or oscilloscope
- together with accessory RT 650.40: familiarisation with and use of I&C software

Description

- experimental introduction to control engineering using an example of temperature control
- construction of the system with components commonly used in industry
- digital controller with freely selectable parameters: P, I, D and all combinations
- optional I&C software RT 650.40 via USB

This experimental unit provides a comprehensive experimental introduction to the fundamentals of control engineering using an example of temperature control.

All components are clearly laid out on a vertical front panel. The large-format process schematic provides an aid to understanding.

The system comprises two water circuits. In the secondary circuit fresh water is heated up by a heat exchanger. The temperature is measured by a temperature sensor at the fresh water outlet. The outlet temperature of the fresh water is controlled by the flow rate of warm water in the primary circuit. The primary circuit comprises an electrically heated tank, a pump and an electromagnetic proportional valve as the actuator.

Both circuits include rotameters. The controller used is a state-of-the-art digital industrial controller. A ball valve in the secondary circuit enables defined disturbance variables to be generated. The controlled variable X and the manipulating variable Y can be tapped as analogue signals at lab jacks. This enables external recording equipment, such as a plotter or an oscilloscope, to be connected.

An instrumentation and control software (RT 650.40) with interface module (USB) is available as an accessory. This enables the key process variables to be represented, and control functions executed.

RT 644

Temperature control demonstration unit



1 controller, 2 control valve, 3 thermometer, 4 rotameter, 5 pump, 6 heater with thermostat, 7 tank, 8 plate heat exchanger, 9 ball valve with scale, 10 temperature sensor at fresh water outlet

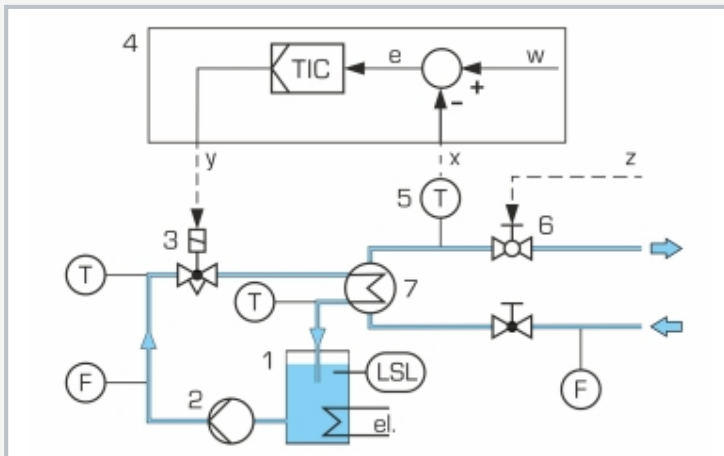

1 heated tank, 2 pump, 3 actuator: control valve, 4 digital industrial controller, 5 measuring element: temperature sensor, 6 generate disturbance variables via ball valve, 7 plate heat exchanger;

x controlled variable: temperature, y manipulated variable: degree of opening of control valve, z disturbance variable: degree of opening of ball valve, w reference variable: input values, e control deviation, F flow, T temperature, LSL level switch

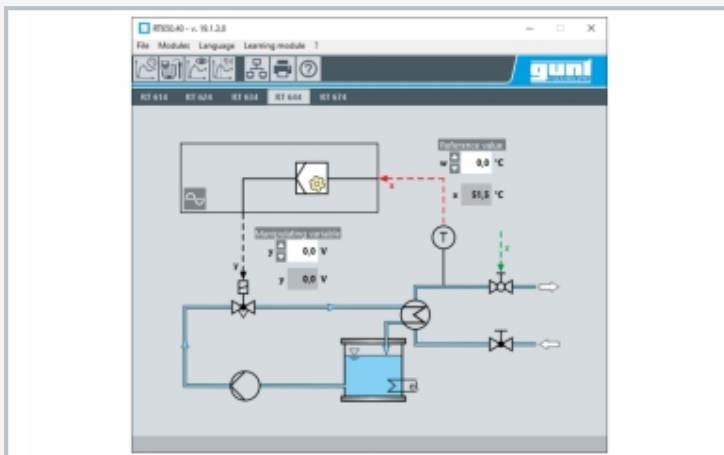

Screenshot of optional I&C software RT 650.40

Specification

- [1] experimental unit for control engineering experiments
- [2] temperature control with plate heat exchanger and 2 water circuits
- [3] primary circuit with electrically heated tank, pump, control valve, rotameter and protection against lack of water
- [4] secondary circuit with fresh water connection, temperature transducer, rotameter
- [5] ball valve to generate disturbance variables in fresh water circuit
- [6] plate heat exchanger, 30 plates
- [7] control valve: electromagnetic proportional valve
- [8] digital industrial controller, freely parameterisable
- [9] large process schematic on front panel
- [10] process variables X and Y accessible as analogue signals via lab jacks

Technical data

Tank

- stainless steel
- capacity: 15L

Heater

- power output: 2kW
- thermostat: 20...80°C

Pump, 3-stage

- max. flow rate: 70L/min
- max. head: 5,5m

Temperature sensor: Pt100: -50...400°C

2x dial-gauge thermometers (bimetal type): 0...80°C

2x rotameters: 30...320L/h

Electromagnetic proportional valve: $Kvs: 0,8m^3/h$

Digital controller, can be parameterised as P, PI or PID controller

Process variables as analogue signals: 0...10V

Connection of external recording devices (e.g. oscilloscope, line recorder) via lab jacks

230V, 50Hz, 1 phase

230V, 60Hz, 1 phase

120V, 60Hz, 1 phase

UL/CSA optional

LxWxH: 1000x500x1070mm

Weight: approx. 75kg

Required for operation

Fresh water connection approx. 350L/h

Scope of delivery

- 1 experimental unit
- 1 set of laboratory cables
- 1 set of instructional material

RT 644

Temperature control demonstration unit

Optional accessories

| | | |
|-----------|-----------|---|
| 080.65040 | RT 650.40 | I&C software for RT 614 - RT 674 series |
| 020.30009 | WP 300.09 | Laboratory trolley |