

## RT 450.04

### Controlled system module: temperature



#### Learning objectives/experiments

- planning, setting up, testing, optimising and assessing temperature control loops with different objectives and components
- design and function of different instrumentation and control components
- technical terminology and symbols in industrial control engineering
- practical exercises: implementing process and signal lines
- commissioning and troubleshooting of process engineering systems

#### Description

- **main element in constructing a temperature control loop**
- **rapid installation into the RT 450 base module by modular panel assembly**

The RT 450.04 controlled system module is a panel-mounted ready-to-install element. In conjunction with other modular control components, it enables temperature control systems with different characteristic features to be constructed and investigated.

The panel is mounted on the frame of the base module RT 450. The main elements of the controlled system module are: an electric heater installed in a section of pipe, and a plate heat exchanger between the primary and secondary water circuits. The heater can either be operated by a switching controller and so act as the control loop actuator, or can operate in continuous duty as a pure energy source. In operation as a continuous controller, with the heater as the energy source, a choice of two different valves (pneumatic or electric) can be used as actuators in the primary circuit.

For safety, the heater features a thermostat and a device to protect it from running dry. The primary circuit (with heater) is connected by pipelines to the water supply of the base module RT 450, while the secondary circuit requires a laboratory water supply for cooling. Counterflow or parallel flow cooling is possible. The connection to the laboratory network is made by quick-release couplings and hoses.

# RT 450.04

## Controlled system module: temperature

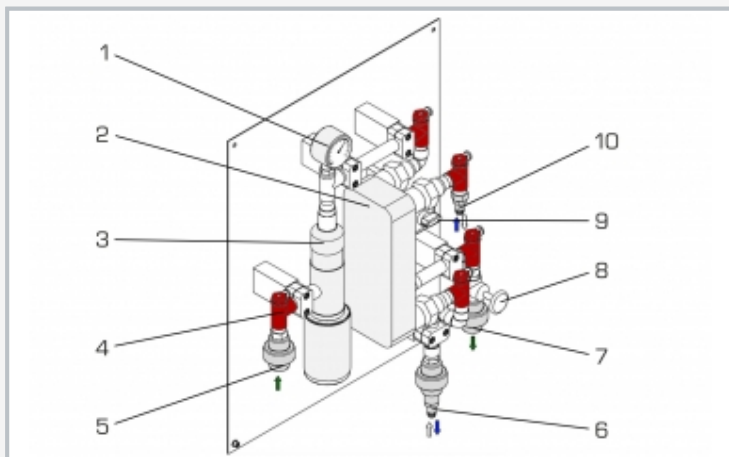

1 thermometer, 2 plate heat exchanger, 3 heater, 4 temperature measurement points, 5 RT 450 inlet, 6 external water circuit connection, 7 return to RT 450, 8 Regulating valve, 9 heater switch, 10 external water circuit connection

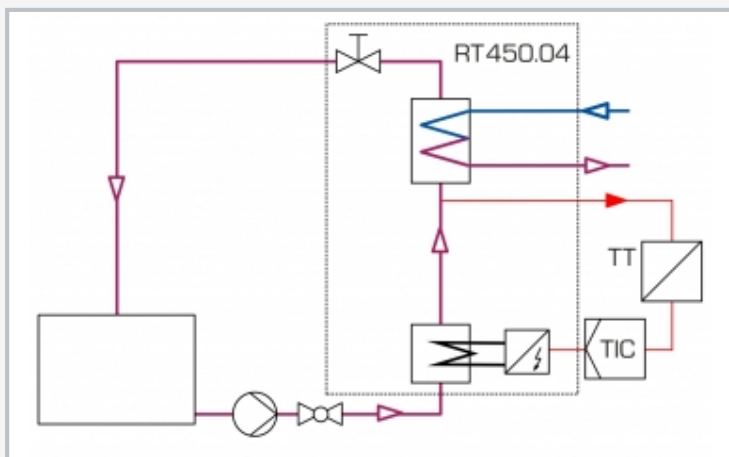

Process schematic for controlled system with heater as actuator and switching controller



The illustration shows the layout of a temperature control system. In addition to the base module RT 450, it includes the following components: RT 450.04 (controlled system module: temperature), RT 450.11 (controller), RT 450.12 (recorder), RT 450.21 (control valve) and RT 450.36 (temperature sensor).

### Specification

- [1] construction of a temperature control loop (in conjunction with other modules of the RT 450 series)
- [2] ready-to-install compact panel assembly
- [3] electric heater with thermostat and dry-running protection
- [4] direct temperature display at heater outlet with bi-metallic thermometer
- [5] heater is either an actuator or a continuous heater
- [6] plate heat exchanger, operating in counter-flow or parallel-current mode
- [7] primary circuit with heater and heat exchanger, connected to water supply of base module RT 450
- [8] flow of primary circuit controlled by hand-operated valve
- [9] secondary circuit of heat exchanger connected to laboratory water supply

### Technical data

Plate heat exchanger

- number of plates: 20
- heat transfer surface: 0,72m<sup>2</sup>
- flow rate: max. 3m<sup>3</sup>/h

Heater with thermostat and dry-running protection

- power output: 2kW
- temperature limitation by thermostat: 65°C

Thermometer at heater outlet: 0...100°C

LxWxH: 510x200x650mm

Weight: approx. 20kg

### Required for operation

water connection: max. 3m<sup>3</sup>/h

### Scope of delivery

- 1 heater and 1 plate heat exchanger mounted on panel, complete with piping, valve, safety elements, temperature sensor fixtures, connections to RT 450 piping system

# RT 450.04

## Controlled system module: temperature

### Required accessories

080.45000	RT 450	Process Automation Training System: Base Module
Control with pneumatically driven control valve		
080.45021	RT 450.21	Control valve, pneumatically driven, Kvs 1,0
080.45010	RT 450.10	Continuous controller module
or		
080.45042	RT 450.42	PLC module with software
Control with electrically driven control valve		
080.45011	RT 450.11	Switching controller module
080.45024	RT 450.24	Control valve, electrically driven, Kvs 1,0
or		
080.45042	RT 450.42	PLC module with software
Sensor		
080.45036	RT 450.36	Temperature sensor Pt100
or		
080.45037	RT 450.37	Thermocouple (K) with head transmitter

### Optional accessories

080.45014	RT 450.14	Software for controller configuration
080.45012	RT 450.12	Chart recorder module
080.45013	RT 450.13	Digital display
080.45040	RT 450.40	Visualisation software
with		
080.45041	RT 450.41	Profibus DP module for controller
or		
080.45043	RT 450.43	Profibus DP module for PLC